

# INVITATION FOR BID

## FINAL BID PACKAGE

**Project Name: WWTF Aeration Diffuser Replacement**

**IFB Number: IFB 2024-002**

**Bids Due  
Date: 2/13/2024  
Time: 2:00 p.m.**



**Prepared by City of Northglenn Public Works Department  
11701 Community Center Drive  
Northglenn, CO 80233**

**TABLE OF CONTENTS**

**VOLUME 1**

**DIVISION 00 – PROCUREMENT AND CONTRACTING REQUIREMENTS**

INVITATION FOR BID  
INSTRUCTION TO BIDDERS  
BID FORM  
BID SUMMARY  
TRADE CONTRACTOR AGREEMENT  
BOND FORM  
NOTICE OF AWARD  
NOTICE TO PROCEED  
APPLICATION FOR PAYMENT FORM  
REQUEST FOR INFORMATION FORM  
FIELD CHANGE DIRECTIVE FORM  
CHANGE ORDER FORM

**DIVISION 01 – GENERAL REQUIREMENTS**

013300 SUBMITTAL PROCEDURES  
013500 SPECIAL CONDITIONS

**VOLUME 2**

EXHIBIT A – SCOPE OF WORK  
SECTION 1 – BACKGROUND INFORMATION AND PHOTOS  
SECTION 2 – DRAWINGS  
SECTION 3 – EQUIPMENT DATA SHEETS AND START UP PROCEDURES



**BID NO** IFB 2024-002

**ISSUE DATE** January 4, 2024

## INVITATION FOR BID (IFB) COVER SHEET

**BID TITLE:** WWTF Aeration Diffuser Replacement

**SUBMISSION DEADLINE:** 2:00 PM on February 13, 2024

**SUBMIT BID TO:** City Clerk's Office  
11701 Community Center Dr  
Northglenn CO 80233  
or  
[bids@northglenn.org](mailto:bids@northglenn.org)

**CONTACT:** Eric Czaikowski

**EMAIL:** eczaikowski@northglenn.org

**PHONE:** 720-642-0552

Bidding instructions and drawings are available at the Rocky Mountain E-Purchasing website or at: [https://www.northglenn.org/government/bids\\_with\\_the\\_city.php](https://www.northglenn.org/government/bids_with_the_city.php)

**MANDATORY PREBID CONFERENCE:** Yes

**DATE & TIME:** January 25, 2024 at 10:00 AM

**LOCATION:** Northglenn Waste Water Treatment Facility - 5445 County Rd 2, Northglenn, CO 80603

The undersigned hereby affirms that (1) they are a duly authorized agent of the vendor, (2) they have read all terms and conditions, requirements, and instructions of this bid as stated or implied, (3) the vendor warrants that they are familiar with all provisions of the contract documents and technical specifications which were made available in conjunction with this solicitation and fully understands and accepts them unless specific variations have been expressly listed in their offer, (4) that the offer is being submitted on behalf of the vendor in accordance with any terms and conditions set forth in this document, and (5) that the vendor listed on the bid submission must match all contract and insurance documents submitted upon award.

### PRINT OR TYPE YOUR INFORMATION

Company \_\_\_\_\_ Fax Number \_\_\_\_\_  
Address \_\_\_\_\_ City, State Zip \_\_\_\_\_  
Contact Person \_\_\_\_\_ Title \_\_\_\_\_  
Email \_\_\_\_\_ Phone \_\_\_\_\_  
Signature \_\_\_\_\_  
Print Name \_\_\_\_\_

# INSTRUCTIONS TO BIDDERS

1. **BID NO:** IFB 2024-002

2. **BID TITLE:** WWTF Aeration Diffuser Replacement

3. **PURPOSE OF SOLICITATION:**

The WWTF has three aeration basins that use a sanitary aeration diffuser system. The diffuser system has become degraded with age and has reached the end of its life-cycle. The scope of work is shown in detail in Appendix A: Scope of work, and generally includes complete removal and replacement of all PVC aeration diffuser equipment, including diffuser heads, PVC laterals and manifolds. Stainless steel support structures are in good condition but will be evaluated during construction and replaced if necessary.

4. **SCHEDULE OF ACTIVITIES:** The following schedule of activities delineates the timing of the solicitation and the estimated project schedule. These dates may be subject to change at the City's discretion.

<u>January 4, 2024</u>	<u>Invitation for Bid Issuance</u>
<u>January 25, 2024 @ 10:00 a.m.</u>	<u>Mandatory Pre-Bid Conference</u>
<u>February 1, 2024 @ 5:00 p.m.</u>	<u>Information/Question Period Ends</u>
<u>February 5, 2024</u>	<u>Addendum Issuance</u>
<u>February 13, 2024 @ 2:00 p.m.</u>	<u>Bid Submission Deadline</u>
<u>February 2024</u>	<u>Notice of Award</u>
<u>March 2024</u>	<u>Notice to Proceed</u>
<u> </u>	<u> </u>
<u> </u>	<u> </u>
<u> </u>	<u> </u>

5. **BID SUBMITTAL REQUIREMENTS:** Vendors must provide the following information.

- **Cover Sheet.** Include the completed Cover Sheet.
- **Prices.** Prices must be provided on the forms provided. The vendor shall not alter forms (e.g. add or modify categories for posting prices offered) unless expressly permitted to do so. No other form shall be accepted.
- **Submission Timeline.** It is the responsibility of the submitting vendors to ensure timely receipt by the City. The City reserves the right to reject any late submittals. Bids must be received no later than 2:00 PM on February 13, 2024.

6. **INTERPRETATION OF DOCUMENTS AND SPECIFICATIONS:** Wherever the word "contract" appears, it shall be held to include all the documents as listed. No less than all of the parts of the contract documents shall constitute the formal contract. If any person contemplating submitting a bid for the proposed contract is in doubt as to the true meaning of any part of specifications, schedules, or information sheets or the proposed contract documents, they may submit to the project manager a written request for an interpretation thereof. The person submitting the request will be responsible for its prompt and actual delivery. Any interpretation of such documents will be made only by an addendum duly issued, and a copy of such addendum will be mailed or delivered to each person receiving a set of such documents. The City will not be responsible for any explanation or interpretation of such documents which anyone presumes to make on behalf of the City.

- 7. TERMS AND CONDITIONS:** As set forth in the contract agreements and any supplemental, the following terms and conditions will apply to this Invitation for Bid, each vendor's bid and to the negotiations, if any, of any said contract. The City will consider specific recommended changes that clarify the intent of the agreement. **The City will not consider contract changes that have not been specifically identified in your proposal response.** A general statement suggesting that, if selected, you reserve the right to discuss contract issues at a later date will not be accepted and will be grounds for disqualification. Submission of a bid in response to this IFB indicates the vendor's acceptance of the terms and conditions contained in this document and the contract.
- 8. BIDDER EXPENSES:** The City of Northglenn will not be responsible for any expenses incurred by any vendor in preparing and submitting an offer.
- 9. BID:** All bids must be made on the forms provided. No alterations in bids or in the printed forms thereof, by erasures, deletions, or interpolations will be acceptable unless each alteration is signed or initialed by the vendor. If initialed, the City may require the vendor identify the alteration so initialed. If mailed or delivered, each bid must be enclosed in a sealed envelope labeled with the words **WWTF Aeration Diffuser Replacement** - IFB 2024-002  
The bid shall be submitted to the City of Northglenn, Office of the City Clerk, 11701 Community Center Drive, Northglenn, Colorado 80233-8061.
- 10. WITHDRAWAL:** A vendor may withdraw their bid at any time prior to the expiration of the final date and time set for receipt of bids. Withdrawal notification must be in written form, and must be received in the Offices of the City Clerk prior to the closing date and time.
- 11. IRREVOCABILITY:** Following the time of closing, all bids will become irrevocable offers to the City and will remain as such until 90 days from date of submission. By submission of a bid, the vendor agrees to enter into a contract. In addition all quoted prices will be firm and valid up to 90 days from date of submission. The City may, in its sole discretion, release any bid and return any bonds if applicable prior to the 90 days.
- 12. LATE BIDS:** Any Bids received after the Final date and time for receipt of Bids will not be accepted and will be unopened and discarded without being considered.
- 13. SIGNATURES OF VENDORS:** Each vendor shall sign their bid, using their legal signature and giving their full business address. The person signing the bid must be an officer of the company or partnership. Bids by partnerships shall be signed with the partnership name by one of the members of the partnership or by an authorized representative, followed by the signature and designation of the President, Secretary, or other persons authorized to bind it in the matter. The names of all persons signing should also be printed below the signature. A bid by a person who affixes to their signature the word, "President", "Secretary", "Agent" or other designation without disclosing their principal, may be held to be a bid of the individual signing. When requested by the City, satisfactory evidence of the authority of the officer signing in behalf of the corporation shall be furnished. Bids submitted electronically are to be typed in lieu of written signature (see the cover letter).
- 14. OPEN RECORDS ACT:** Notwithstanding any language contained in a bid to the contrary, all bids submitted to the City become the property of the City. Any information considered proprietary should be marked by the vendor and as such and will be kept confidential to the extent provided by law.
- 15. SALES TAX:** Vendors shall not include federal, state, or local excise, sales or use taxes in prices offered, as the City is exempt from payment of such taxes.
- 16. MISTAKES IN BIDDING INSTRUCTIONS:** If the City makes a mistake in drafting the bidding instructions or any other contract documents, the City reserves the right to reject any or all bids, or to require that vendors submit an alternate bid with adjustments made to correct the error(s). Such errors will be set forth in an addendum. If the vendor has already been selected and has started performing work under the contract, and the City then discovers a mistake in the contract documents for which the City is responsible, the City may opt to reform the contract. If the mistake causes the vendor to receive compensation for materials not used in the work or for labor that would not be required for the work, the contract price shall be decreased

proportionally. If the mistake causes the vendor to fail to bid on work which must be performed in order to properly complete the contract, the City may increase the contract price to equal the proportionate increase in the cost of required materials and labor caused to the vendor. In the alternative, the City may solicit bids for such additional work, or the City may reassign such additional work to another vendor, as the City deems appropriate. Nothing in this provision shall apply to mistakes made by the vendor in completing the bid form or in performing the contract.

- 17. BID RESULTS:** Vendors desiring to know bid results must enclose a self-addressed, stamped envelope with their bid. A bid summary sheet will be mailed after the bid opening. No bid results will be given over the telephone. Vendors attending the bid opening will receive a copy of the results after the opening of the bids.
- 18. ACCEPTANCE OF BID:** It is expressly understood and agreed that the City reserves the right to reject any or all bids, to waive formalities, and accept the bid which appears to be in the City's best interest.
- 19. APPEAL OF AWARD:** Solicitations will be awarded based on multiple criteria, price being just one of the conditions. Vendors can review the solicitation's special terms and conditions for information on evaluation criteria. Vendors may appeal the award decision by submitting, in writing, to the City of Northglenn, a request for reconsideration within 7 calendar days after the posting of the Notice of Intent to Award, provided that the appeal is sought by the vendor prior to the City finalizing a contract with the selected vendor. Vendors who were deemed non-responsive are ineligible to participate in the appeal process.
- 20. DEFENSE OF SUITS:** In case any action at law or suit in equity is brought against the City, any officer, employee, or agent thereof, for or on account of the failure, omission, or neglect of the vendor to do and perform any of the covenants, acts, matters, or things by this contract undertaken to be done or performed, or for the injury or damage caused by the negligence of the vendor or their subcontractors or their or their agents, or in connection with any claim or claims based on the lawful demands of subcontractors, workmen, material, men or suppliers or machinery and parts thereof, equipment, power tools and supplies incurred in the fulfillment of the contract, the vendor shall indemnify and save harmless the City, officers, employees, and agents of the City, of and from all losses, damages, costs (including attorney's fees), expenses, judgments, or decrees whatever arising out of such action of suit that may be brought as aforesaid.
- 21. CONTRACT NEGOTIATIONS:** If the City decides to proceed and to negotiate a contract, the City intends to provide written notification to the vendor whose bid is deemed by the City to be in the best interests of the City and the City will attempt to negotiate a contract with the selected vendor(s) on terms and conditions stated in this IFB or in the successful vendor's bid, but shall also include terms and conditions later negotiated. If the City and the successful vendor are unable to execute a contract and the vendor has been notified that it is the successful vendor then the City may cease all discussions with the (first) successful vendor without any further obligation to that vendor and select another (second) vendor as the successful vendor. If the (second) vendor is rejected, as per the terms above, then the City, without any further obligation to that vendor, may select another (third) vendor as the successful vendor and so on, or the City reserves the right to reject all bids and re-bid.

# BID FORM

---

City of Northglenn  
11701 Community Center Drive  
Northglenn, Colorado 80233-8061

**BID:** Pursuant to the "advertisement for bids" for the above named project, and being familiar with all contractual requirements therefore, the undersigned bidder hereby proposes to furnish all labor, materials, tools, supplies, equipment, transportation, services and all other things necessary for the completion of the contractual work, and perform the work in accordance with the requirements and intent of the contract documents, within the time of completion set forth herein, for, and in consideration of the following prices.

Proposal of \_\_\_\_\_ (hereinafter called **BIDDER**) organized and existing under the laws of the State of \_\_\_\_\_ doing business as \_\_\_\_\_\*.  
To the **CITY OF NORTHGLENN** (hereinafter called **CITY**). In compliance with your advertisement for bids, **BIDDER** hereby proposes to perform WORK on

\_\_\_\_\_ - \_\_\_\_\_

in strict conformance with the **CONTRACT DOCUMENTS**, within the time set forth therein, and at the prices stated below.

By submission of this **BID**, each **BIDDER** certifies, and in case of a joint **BID** each party thereto certifies as to their own organization that this **BID** has been arrived at independently, without consultation, communication, or agreement as to any matter relating to this **BID** with any other **BIDDER** or with any competitor.

**BIDDER** hereby agrees to commence **WORK** under this contract on or before a date to be specified in the **NOTICE TO PROCEED** and to fully complete the **PROJECT** as indicated in the General Conditions.

**BIDDER** acknowledges receipt of the following **ADDENDUM**:

\_\_\_\_\_  
\_\_\_\_\_

\*Insert "a corporation", "a partnership", or "an individual" as applicable.

Sub-contractors (if any): Work they will perform:

1. \_\_\_\_\_ Email: \_\_\_\_\_

2. \_\_\_\_\_ Email: \_\_\_\_\_

3. \_\_\_\_\_ Email: \_\_\_\_\_

Please provide a complete and accurate list of at least three references and contact phone numbers:

1. \_\_\_\_\_ Phone: \_\_\_\_\_

Email: \_\_\_\_\_

2. \_\_\_\_\_ Phone: \_\_\_\_\_

Email: \_\_\_\_\_

3. \_\_\_\_\_ Phone: \_\_\_\_\_

Email: \_\_\_\_\_

Respectfully submitted,

(Seal, if Bid is by a Corporation)

\_\_\_\_\_  
Attest

\_\_\_\_\_  
Signature

\_\_\_\_\_  
Address

\_\_\_\_\_  
Title

\_\_\_\_\_  
Date

\_\_\_\_\_  
License Number  
(If Applicable Signature)

\_\_\_\_\_  
Phone Number



## BID SPECIFICATIONS

---

**SEE EXHIBIT A**

## BID SUMMARY

**(Vendor Name)**

Hereby submits to the City of Northglenn, Colorado the following bid items complete and in place as specified for the:  
**WWTF Aeration Diffuser Replacement - IFB 2024-002**

Item No.	Description	Quantity	Unit	Unit Cost	Total Cost
1	Remove and replace in kind, complete aeration diffuser replacement system in Aeration Basin 1. Inclusive of all labor, materials, equipment, and incidentals to replace the aeration diffuser system to the limits shown in Exhibit A.	1	LS	\$ -	\$ -
2	Remove and replace stainless steel support bases and drill new anchor hole(s) in Aeration Basin 1 as shown in Exhibit A, as necessary.	30	EA	\$ -	\$ -
Bid Item Total					\$ -

Bid Alternate					
BA-1	Remove and replace in kind, complete aeration diffuser replacement system in Aeration Basin 2. Inclusive of all labor, materials, equipment, and incidentals to replace the aeration diffuser system to the limits shown in Exhibit A.	1	LS	\$ -	\$ -
BA-2	Remove and replace stainless steel support bases and drill new anchor hole(s) in Aeration Basin 2 as shown in Exhibit A, as necessary.	30	EA	\$ -	\$ -
BA-3	Remove and replace in kind, complete aeration diffuser replacement system in Aeration Basin 3. Inclusive of all labor, materials, equipment, and incidentals to replace the aeration diffuser system to the limits shown in Exhibit A.	1	LS	\$ -	\$ -
BA-4	Remove and replace stainless steel support bases and drill new anchor hole(s) in Aeration Basin 3 as shown in Exhibit A, as necessary.	30	EA	\$ -	\$ -
Bid Alternate Total					\$ -

**TRADE CONTRACTOR AGREEMENT**

TABLE OF CONTENTS

**ARTICLE 1 - GENERAL PROVISIONS AND SERVICES..... 1**

**ARTICLE 2 - DEFINITIONS..... 1**

**ARTICLE 3 - DESCRIPTION OF WORK AND SERVICES..... 3**

**ARTICLE 4 – TRADE CONTRACTOR'S CONSTRUCTION SCHEDULE..... 13**

**ARTICLE 5 - TIME FOR COMPLETION AND LIQUIDATED DAMAGES ..... 15**

**ARTICLE 6 - CONTRACT SUM ..... 17**

**ARTICLE 7 - CORRECTION OF WORK ..... 17**

**ARTICLE 8 - TEMPORARY FACILITIES AND SERVICES ..... 19**

**ARTICLE 9 - INDEMNIFICATION AND INSURANCE ..... 19**

**ARTICLE 10 - PERFORMANCE, LABOR AND MATERIAL PAYMENT BONDS..... 19**

**ARTICLE 11 – CLAIMS AND DISPUTES ..... 20**

**ARTICLE 12 - RESOLUTION OF CLAIMS AND DISPUTES ..... 24**

**ARTICLE 13- TERMINATION..... 22**

**ARTICLE 14 - SIMULTANEOUS WORK BY OTHERS ..... 26**

**ARTICLE 15 - SUBCONTRACTING ..... 27**

**ARTICLE 16 - GUARANTY ..... 25**

**ARTICLE 17 - SALES TAX ..... 28**

**ARTICLE 18 - MISCELLANEOUS PROVISIONS ..... 28**

**ARTICLE 19 - ATTACHMENTS, SCHEDULES AND SIGNATURES ..... 31**

## TRADE CONTRACTOR AGREEMENT

THIS AGREEMENT is made and entered into this \_\_\_\_\_ day of \_\_\_\_\_, 20\_\_\_\_, by and between the City of Northglenn, State of Colorado, a Colorado home rule municipal corporation, hereinafter referred to as the "City" or "Owner" and \_\_\_\_\_, hereinafter referred to as the "Trade Contractor".

### ARTICLE 1 - GENERAL PROVISIONS AND SERVICES

- A. The Trade Contractor will commence and fully complete the construction of the Project, which is described in **Exhibit A**, which is attached hereto and made a part hereof ("Project").
- B. The Trade Contractor will furnish all of the material, supplies, tools, equipment, labor and other services necessary for the construction and completion of the project described herein.
- C. The Trade Contractor will commence the work required by the contract documents within ten (10) calendar days after the date of the notification to proceed and will complete the same within \_\_\_\_\_ ( \_\_\_\_\_ ) day, unless the period for completion is extended otherwise by the contract documents. The Trade Contractor agrees to pay as liquidated damages, and not as a penalty, the sum of \_\_\_\_\_ (\$ \_\_\_\_\_ ) for each consecutive calendar day's delay in completing this Contract after the completion date specified herein, excluding any approved extensions of time because of unavoidable delay.
- D. The Trade Contractor agrees to perform all of the work described in the contract documents and to comply with the terms therein for an amount not to exceed \_\_\_\_\_ (\$ \_\_\_\_\_ ) as described in Article 5 of this Agreement.

### ARTICLE 2 - DEFINITIONS

- A. Wherever used in the contract documents, the following terms shall have the meanings indicated which shall be applicable to both the singular and plural thereof:
1. Addenda - Written or graphic instruments issued prior to the execution of the Agreement which modify or interpret the contract documents, drawings and specifications, by additions, deletions, clarifications or corrections.
  2. Architect - The Architect shall be \_\_\_\_\_
  3. Bid - The offer or proposal of the bidder submitted in the prescribed form setting forth the prices for the work to be performed.
  4. Bidder - Any person, firm or corporation submitting a bid for the work.
  5. Bonds - Bid, performance and payment bonds and other instruments of security, furnished by the Trade Contractor and his surety in accordance with the contract documents.
  6. Change Order - A written order to the Trade Contractor authorizing an addition, deletion or revision in the work within the general scope of the contract documents or authorizing an adjustment in the contract price and/or contract time.
  7. Contract Documents - The contract, including advertisement for bids, information for bidders, bid, bid bond agreement, bid schedule, labor and material, payment bond, performance bond, notice of award, notice to proceed, change order, general conditions, special conditions, general specifications, special specifications, scopes of work, addenda, drawings, schedules and any and all other documents or papers included or referred to in the foregoing documents are part of the Contract Documents
  8. Contract Price - The total monies payable to the Trade Contractor under the

terms and conditions of the contract documents.

9. Contract Time - The number of calendar days stated in the contract documents for the completion of the work.

10. Date of Award - Date of award of contract shall mean the date formal notice of such award, approved by the Owner, has been delivered to the intended awardee, or mailed to him at the main business address shown in his proposal by the Owner or it's authorized representative.

11. Day or Days - Unless herein otherwise expressly defined, "day" shall mean calendar day or days.

12. Drawings, Plans or Contract Documents - The part of the contract documents which shows the characteristics and scope of the work to be performed and which has been prepared or approved by the Engineer and/or Architect.

13. Engineer shall be

14. Field Order - A written order effecting a change in the work not involving an adjustment in the contract price or an extension of the contract time, issued by the Engineer or the Owner to the Trade Contractor during construction.

15. Major Equipment or Major Equipment Items - Installation of major equipment to be furnished and placed under the contract awarded to the Trade Contractor and/or installations of major equipment to be furnished by the Owner and received, unloaded, stored, and placed under the contract awarded to the Trade Contractor.

16. Notice of Award - The written notice of the acceptance of the bid from the Owner to the successful bidder.

17. Notice to Proceed - Written communication issued by the Owner to the Trade Contractor authorizing him to proceed with the work and establishing the date of commencement of the work.

18. Owner or City - The City of Northglenn, Colorado, a home rule municipality. The Public Works Director of the Owner, or his designee, is the Owner's representative.

19. Project - Construction of the project described in **Exhibit A**.

20. Shop Drawings - All drawings, diagrams, illustrations, brochures, schedules, and other data which are prepared by the Trade Contractor, a subcontractor, manufacturer, supplier or distributor, which illustrate how specific portions of the work shall be fabricated or installed.

21. Site - The lands and other places on, under, in, or through which the work is to be executed or carried out and any other lands or places provided by the Owner for the purposes of the contract together with such other places as may be specifically designed in the contract documents as forming part of the site.

22. Special Conditions - Supplemental conditions that apply to specific aspects of the project or modifications to the general conditions that are to be adhered to in the project.

23. Subcontractor - An individual, firm or corporation having a direct contract with the Trade Contractor or with any other subcontractor for the performance of a part of the work at

the site.

24. Substantial Completion - That date as certified by the Owner when the construction of the project or a specified part thereof is sufficiently completed, in accordance with the contract documents, so that the project or specified part can be utilized for the purposes for which it is intended.

25. Suppliers - Any person, supplier, or organization who supplies materials or equipment for the work, including that fabricated to a special design, but who does not perform labor at the site. A supplier is not a subcontractor who purchases an item of equipment from a manufacturer.

26. Trade Contractor - The person, firm or corporation with whom the City of Northglenn has executed this Agreement.

27. Work - All labor necessary to produce the construction required by the contract documents, and all materials and equipment incorporated or to be incorporated in the project. The work and the project are used interchangeably to mean the same thing.

28. Written Notice - Any notice to any party of the Agreement relative to any part of the Agreement in writing and considered delivered and the service thereof completed when posted by certified or registered mail to the said party at his last given address, or delivered in person to said party or his authorized representative on the work.

### **ARTICLE 3 - DESCRIPTION OF WORK AND SERVICES**

#### **Section 1. Drawings and Specifications.**

- A. The intent of the drawings and specifications is that the Trade Contractor shall furnish all labor, materials, tools, equipment, and transportation necessary for the proper execution of the work in accordance with the contract documents and all incidental work necessary to complete the project in an acceptable manner, ready for use, occupancy or operation by the Owner.
- B. Up to three (3) copies of the drawings and specifications will be furnished to the Trade Contractor without charge upon request, and any additional copies which the Trade Contractor may request will be furnished at the cost of reproduction. The drawings and specifications are to be used only in connection with the work specified herein and, with the exception of the signed contract set and As-Built drawings, are to be returned at the completion of the contract.
- C. In case of conflict between the drawings and specifications, the drawings will govern. In case of conflict between the special specifications and the general specifications, the special specifications shall govern. Figure dimension on drawings will govern over scale dimensions, and detailed drawings will govern over general drawings. Notwithstanding the above, a document which is more restrictive or requires greater responsibility or increased compliance by the Trade Contractor shall govern.
- D. Any discrepancies found between the drawings and specifications and site conditions or any inconsistencies or ambiguities in the drawings or specifications shall be immediately reported to the Owner, in writing, who will promptly resolve such inconsistencies or ambiguities in writing. Work done on unreported discrepancies, inconsistencies or ambiguities by the Trade Contractor shall be done at the Trade Contractor's risk.
- E. The Trade Contractor may be furnished additional instructions and detail drawings, by the Owner, as necessary to carry out the work required by the contract documents. All additional

instructions and detail drawings shall be issued to the Trade Contractor by the Owner.

F. The additional drawings and instructions thus supplied will become a part of the contract documents. The Trade Contractor shall carry out the work in accordance with the additional detail drawings and instructions.

Section 2. Materials, Services and Facilities.

A. It is understood that, except as otherwise specifically stated in the contract documents, the Trade Contractor shall provide and pay for all materials, labor, tools, equipment, water, light, power, transportation, supervision, temporary construction of any nature and all other services and facilities of any nature whatsoever necessary to execute, complete and deliver the work within the specified time.

B. In addition to the requirements for major equipment items previously given, within fourteen (14) days after execution of the Contract, the Trade Contractor shall submit to the Owner and Engineer a complete listing of the manufacturers of each item of equipment or assembly fabricated off the site which he proposed to furnish for the project, together with sufficient information, including shop assembly and detail drawings, manufacturers' specifications and performance data, to demonstrate clearly that the materials and equipment to be furnished comply with the provisions and intent of the contract documents. If the information shows any deviation from the Contract requirements, the Trade Contractor shall advise the Engineer and Owner of the deviation and state the reason for it in writing.

C. Only first-class materials and materials which conform to the requirements of the specifications shall be incorporated in the work. All materials shall be new unless specified to be otherwise.

D. When requested by the Owner, the Trade Contractor shall furnish a written statement of the origin, composition, and manufacturer of any or all materials (manufactured, produced or grown) that are to be used in the work. The sources of supply of each material used will be approved by the Owner before delivery is started. If, at any time, sources previously approved, fail to produce materials acceptable to the Owner, the Trade Contractor shall furnish materials from other sources.

E. Materials and equipment shall be so stored as to insure the preservation of their quality and fitness for the work. Stored materials and equipment to be incorporated in the work shall be located so as to facilitate prompt inspection.

F. Manufactured articles, materials, and equipment shall be applied, installed, connected, erected, used, cleaned and conditioned as directed by the manufacturer.

G. Materials, supplies, and equipment shall be in accordance with samples submitted by the Trade Contractor and approved by the Engineer or Architect.

H. Materials, supplies or equipment to be incorporated into the work shall not be purchased by the Trade Contractor or the subcontractor subject to a chattel mortgage or under a conditional sale contract or other agreement by which an interest is retained by the seller.

I. The Trade Contractor shall retain, for the benefit of the Owner, all materials and supplies that are purchased for the project but are not used as a part of the project. The Owner may take any of the materials and supplies that are used in the project for any City purpose. Any materials and supplies not taken by the Owner shall be removed from the project site by the Trade Contractor.

Section 3. Shop Drawings.

A. The Trade Contractor shall submit shop drawings, samples and O&M manuals as may be necessary for the prosecution of the work as required by the contract documents on a timely basis so that the project schedule is not affected. The Engineer will promptly review all shop drawings. All such drawings will be approved and signed by the Engineer, and will be null and void unless authorized by such signature. The Engineer's approval of any shop drawing will not release the Trade Contractor from responsibility for deviations from the contract documents. The approval of any shop drawings which substantially deviates from the requirements of the contract documents shall be evidenced by a change order.

B. All drawings and details on items of major equipment will be reviewed by the Engineer only after the complete set of drawings and details covering the entire equipment package to be furnished under a particular major equipment item are submitted. Drawings submitted on a piecemeal basis covering only parts of the equipment package will be held for checking until the entire set of drawings are received.

C. The Trade Contractor shall also submit to the Engineer shop drawings showing all necessary detail for the proper installation of materials into the completed work, as provided by this Agreement.

D. The Trade Contractor shall make any indicated corrections on the drawings returned and shall resubmit corrected drawings until final approval is obtained.

E. The Trade Contractor shall have no claims for damages or extension of time on account of any delay in the work resulting from the rejection of material or from review, revision and resubmittal of drawings when the review, revision and resubmittal is due to changes to the original design documents, and other data for approval by the Engineer.

F. Each shop drawing shall be dated and shall be identified with the name of the project, the division, if any, the Contract item number, and the name of the Trade Contractor.

G. When submitted for the Engineer's review, shop drawings shall bear the Trade Contractor's certification that he has reviewed, checked and approved the shop drawings and that they are in conformance with the requirements of the contract documents.

H. The Trade Contractor shall submit the shop drawings in accordance with the general requirements.

I. Portions of the work requiring a shop drawing or sample submission shall not begin until the shop drawing or submission has been approved by the Engineer. A copy of each approved sample shall be kept in good order by the Trade Contractor at the site and shall be available to the Engineer.

J. By approving and submitting shop drawings and samples, the Trade Contractor thereby represents that he has determined and verified all field measurements, field construction criteria, materials, catalog numbers and similar data, or will do so, and that he has checked and coordinated each shop drawing and sample with the requirements of the work and of the contract documents.



Section 4. Records, Accounts and Audits.

A. The Trade Contractor agrees to keep one complete set of records and books of account on a recognized cost accounting basis (satisfactory to the Engineer), showing all expenditures, of whatever nature, made pursuant to the provisions of this Contract.

B. The Trade Contractor shall furnish the Engineer and Owner with such records, information and data as may be reasonable. The Engineer and Owner shall at all reasonable times be afforded the opportunity to inspect and/or audit the above-specified books and records of said Trade Contractor.

Section 5. Inspection and Testing.

A. All materials and equipment used in the construction of the project will be subject to adequate inspection and testing in accordance with generally accepted standards.

B. The Trade Contractor shall give sufficient advance notice of placing orders to permit tests to be completed before materials are incorporated in the work.

C. The Owner will provide all inspection and testing services required by the Contract Documents, unless specifically noted in the contract specifications for special inspection and testing services, such as, by way of example, welding inspections on off-site assembly.

D. Neither observations by the Engineer, and Owner, tests nor approvals by persons other than the Engineer and Owner will relieve the Trade Contractor from his obligations to perform the work in accordance with the requirements of the contract documents.

E. The Engineer, the Owner, and their representatives will at all times have access to the work and to locations where materials or equipment are being manufactured, stored, or prepared for use under these contract documents, and they shall have full facilities for unrestricted inspection of such materials, equipment, and work including full access to purchasing and engineering information, but not including prices, to the extent of uncovering, testing, or removing portions of the finished work. The Engineer and Owner shall be furnished with such information as may be required regarding materials used and the process of manufacture for the various items of equipment. Inspections by the Engineer and Owner of equipment or materials during its manufacture will be performed by or for the Owner solely in an effort to detect discrepancies and defects as early as possible, when they can be most readily corrected, and the work thereby expedited. No acceptance of equipment or materials will be construed to result from such shop inspections by the Engineer and Owner. Any inspections or tests or waivers thereof will not relieve the Trade Contractor of responsibility for meeting all requirements of these contract documents.

F. In addition, authorized representatives and agents of any participating federal or state agency shall be permitted to inspect all work, materials, payrolls, records of personnel, invoices of materials, and other relevant data and records. The Trade Contractor shall provide proper facilities for such access and observation of the work and also for any inspection or testing thereof.

G. In case of disputes between the Trade Contractor and the Engineer as to materials furnished or manner of performing the work, the Owner will have authority to reject materials or suspend the work until the question at issue can be decided by the Owner. The Owner is authorized to revoke, alter, enlarge, relax or release any requirements of these specifications, and to approve or accept any portion of the work, and to issue instructions contrary to the drawings and specifications.

Section 6. Construction Review

A. The Engineer will periodically observe the construction of all work covered by this Contract. The Engineer, on behalf of the Owner, shall be authorized to determine the amount or quantities of the several items of work which are to be paid for under this Contract; to order field changes within the scope of the Contract and to render decisions on any questions which may arise relative to the execution of the work covered by this Contract. The Engineer does not have authority to suspend work on the project. The Trade Contractor shall not suspend any portion of the work nor resume suspended work without the written authority of the Owner.

B. Neither Engineer's authority to act under the Contract nor any decision made by Engineer in good faith either to exercise or not exercise such authority shall give rise to any duty or responsibility of the Engineer to the Trade Contractor, any subcontractor, any supplier, or any other person or organization performing any of the Work, or to any surety for any of them.

C. Whenever in the drawings, plans or Contract Documents the terms "as ordered", "as directed", or the adjectives "reasonable", "suitable", "acceptable", "proper" or "satisfactory" or adjectives of like effect or import are used to describe a requirement, direction, review or judgment of Engineer as to the work, it is intended that such requirement, direction, review or judgment will be solely to evaluate the work for compliance with the contract documents. The use of any such term or adjective shall not be effective to assign to Engineer any duty or authority to supervise or direct the furnishing or performance of the Work or any duty or authority to undertake responsibility for the project. Neither the Owner nor the Engineer will be responsible for the acts or omissions of Contractor or any Subcontractor, any Supplier, or of any other person or organization performing or furnishing any of the Work.

D. Periodic observation of the work in progress by the Engineer will be done whenever the Contractor is performing work that requires review as determined by the Engineer. The normal working time shall be during a regular 5-day, 40-hour work week, Monday through Friday. If the Trade Contractor elects to work more than 40 hours per week and observation is required during this overtime work as determined by the Engineer, the Engineer shall be paid by the Trade Contractor at the rate as specified herein for all review time required over the normal 5-day, 40-hour week. If the Engineer or his authorized representative is called to the job site to address problems created by the Trade Contractor, he will be paid by the Trade Contractor at the same rate as for overtime review as stated above. This payment shall be made by a credit to the Owner, and then the Engineer shall bill the Owner for the same.

E. If any work has been covered which the Engineer has not been specifically requested to observe prior to its being covered, or if the Engineer considers it necessary or advisable that covered work be inspected or tested by others, the Trade Contractor at the Engineer's request shall uncover, expose or otherwise make available for observation, inspection or testing as the Engineer may require, that portion of the work in question, furnishing all necessary labor, materials, tools and equipment. If it is found that such work is defective, the Trade Contractor shall bear all the expenses of such uncovering, exposure, observation, inspection and testing and of satisfactory reconstruction. If, however, such work is not found to be defective, the Trade Contractor will be allowed an increase in the contract price or an extension of the contract time, or both, directly attributable to such uncovering, exposure, observation, inspection, testing and reconstruction and an appropriate change order will be issued.

Section 7. Surveys, Permits and Regulations.

A. The Owner will furnish any existing land surveys in the Owner's possession. Provided however, the Trade Contractor shall perform all necessary land surveys to complete the work required by this Agreement. The Trade Contractor shall provide detailed construction staking.

B. At the beginning of the construction or as the work progresses, the Trade Contractor shall be responsible for the installation of property corners and the setting of benchmarks.

C. Benchmarks and survey stakes shall be preserved by the Trade Contractor and in case of their destruction, or removal by him, his employees, or others, they shall be replaced at the Trade Contractor's expense and his Sureties shall be liable therefor.

D. The Trade Contractor shall be responsible for elevations used in computing his bid.

E. The Trade Contractor shall secure and pay for all necessary permits, fees and licenses in connection with the performance of its work and shall pay all municipal and other governmental fees in connection therewith except those expressly provided by the specifications as being the responsibility of the Owner, and shall furnish at its expense any and all bonds and cash or other deposits required by law or required by any lawful body having the right to make demand therefor.

F. The Owner will provide rights-of-way and permanent and temporary easements as shown on the plans for construction purposes. Any additional land actually needed by the Trade Contractor for the performance of the work, proper location of his plant and equipment, or the storage of materials and supplies for the work, shall be furnished by the Trade Contractor.

Section 8. Protection of Work, Property and Persons.

A. The Trade Contractor shall be responsible for initiating and maintaining all safety precautions and programs in connection with the work. Neither the Owner nor the Engineer will be responsible for Trade Contractor's means, methods, techniques, sequences or procedures of construction, or the safety precautions and programs incident thereto. The Trade Contractor shall take all necessary precautions for the safety of, and shall provide the necessary protection to prevent damage, injury or loss to all employees on the work who may be affected thereby, all the work and all materials or equipment to be incorporated therein, whether in storage on or off the site, and other property at the site or adjacent thereto, including trees, shrubs, lawns, walks, pavements, roadways, structures and utilities not designated for removal, relocation or replacement in the course of construction.

B. The Trade Contractor shall at all times consult with and obtain the approval of the Owner for the storage of material, operation of equipment, placing of temporary structures or dispositions of any surplus or waste materials upon property of the Owner anywhere outside the limits of construction. The Trade Contractor shall comply with all state, federal and local laws related to the storage or placement of any supplies, equipment, structures, or any other materials.

C. The Trade Contractor shall comply with all applicable laws, ordinances, rules, regulations and orders of any public body having jurisdiction. He shall erect and maintain, as required by the conditions and progress of the work, all necessary safeguards for safety and protection. He shall notify owners of adjacent utilities when prosecution of the work may affect them. The Trade Contractor shall remedy at his expense all damage, injury, or loss to any property or person caused, directly or indirectly, in whole or in part, by the Trade Contractor, any subcontractor or anyone directly or indirectly employed by any of them or anyone for whose acts any of them may be liable, except damage or loss attributable to the fault of the contract documents or to the acts or omissions of the Owner or the Engineer or anyone employed by either of them or anyone for whose acts either of them may be liable, and not attributable, directly or indirectly, in whole or in part, to the fault or negligence of the Trade Contractor. Notwithstanding the provisions of C.R.S. § 13-20-802.5(2), for purposes of this Contract, the measure of damages shall never be deemed to be the fair market value of the real property without an alleged construction defect.

D. The Trade Contractor shall observe all rules and regulations of the health department

having jurisdiction and shall take precautions to avoid creating unsanitary conditions.

E. In emergencies affecting the safety of persons or the work or property at the site or adjacent thereto, the Trade Contractor, without special instruction or authorization from the Engineer or Owner, shall act to prevent threatened damage, injury or loss.

F. The Trade Contractor shall at all times conduct and work in such a manner as to cause the least inconvenience and greatest protection to the general public. The Trade Contractor shall furnish and maintain barricades, warning signs, red flags, lights, and temporary passageways as may be necessary to protect the work and to safeguard the public. The cost of furnishing and maintaining the above facilities shall be incidental to the contract and no extra compensation for it will be allowed.

G. Throughout the performance of the work or in connection with this Contract, the Trade Contractor shall construct and adequately maintain suitable and safe crossings over trenches and such detours as are necessary to care for public and private traffic. The material excavated from trenches shall be compactly deposited along the sides of the trench or elsewhere in such a manner as shall give as little inconvenience as possible to the traveling public, to adjoining property owners, to other trade contractors, or to the City.

H. In performing the work, the Trade Contractor shall take the necessary action, including making arrangements with the owners or operators of existing power, cable and telephone lines, fiber-optic and telemetry lines, gas, water, sewer and other utilities or installations that may be encountered, whether privately or publicly owned, to prevent interference with the conditions, operations and maintenance of the respective utilities in a manner satisfactory to the owners, or operators of the respective utilities. Relocation or repair of utilities encountered even though not shown on the plans, shall be the responsibility of the Trade Contractor. The cost of the above measures, including maintaining of guards, watchmen, signals, barricades and temporary structures, making any necessary repairs and other cooperative or corrective work shall be borne by the Trade Contractor and shall be included in the prices bid in the Proposal for the related items of work. Neither the Owner nor the Engineer shall be responsible to the Contractor for the existence of utilities not shown on the plans or drawings and the Trade Contractor remains obligated under this paragraph for all hidden utilities.

I. The Trade Contractor shall be responsible for the preservation of all private or public property along and adjacent to the work and shall take all necessary precautions to prevent damage or injury thereto. Such preservation and protection shall include but not be limited to, trees, stone walls, fences, mailboxes, monuments, irrigation ditches, driveways, road access culverts, underground pipelines and structures. Such preservation and protection shall apply to all underground pipelines and utilities whether public, private or individually owned that are in or adjacent to the right-of-way. When direct or indirect damage is done to public or private property on account of the act, omission, neglect or misconduct in the prosecution or non-prosecution of the work on the part of the Trade Contractor, such property shall be restored by the Trade Contractor at the Trade Contractor's expense to a condition similar or equivalent to that which existed before such damage or injury was done, and brought up to current codes if applicable. The Trade Contractor shall be responsible for making all arrangements at his own expense for moving and operating equipment at temporary crossings of telephone and transmission lines, railroad tracks, irrigation ditches and pipelines.

#### Section 9. Communication with the Owner.

The Trade Contractor shall designate a responsible member of its organization at the site, whose duty shall be designated as the contact person for all communication between the Owner and the Trade Contractor. Said designated representative shall also be responsible to attend such meetings, as may be required to insure coordination and adequate performance of the work.

Section 10. Scope of Work.

The scope of work is described in the contract documents which are appended hereto and incorporated herein by this reference.

Section 11. Trade Contractor's Responsibility.

A. The Trade Contractor shall be responsible for all the work under this Contract until completion and final acceptance by the Owner.

B. The Trade Contractor shall supervise and direct the work. He shall be solely responsible for the means, methods, techniques, sequences and procedures of construction.

C. The Trade Contractor shall employ on the work only such persons who are competent and skilled in their assignments. Any employee who obstructs the progress of the work through incompetence or other means or conducts himself improperly shall be discharged or removed from the work when so requested by the Owner. This section shall not create a duty for the Owner to evaluate or assess the competence or skills of the Trade Contractors employees.

D. The Trade Contractor warrants that all materials and equipment furnished and incorporated by him in the project shall be new, unless otherwise specified, and that all work under this Trade Contract shall be of good quality, free from fault and defects and in conformity with the contract documents. All work not conforming to these standards shall be considered defective. The warranty provided herein shall be in addition to and not in limitation of any other warranty or remedy required by law or by the contract documents.

E. The Trade Contractor agrees that if he should fail or neglect to prosecute the work diligently and properly, or fail to perform any provisions of this Trade Contract, that the Owner, after three (3) days written notice to said Trade Contractor may, without prejudice to any other remedy, make good such deficiencies and may deduct the cost thereof from the payments then or thereafter due to the Trade Contractor pursuant to this Contract.

F. Tools furnished with any equipment may be used when approved by the Owner and shall be turned over to the Owner after completion of the work in a condition acceptable to the Owner. In case of rejection by the Owner, the Trade Contractor shall replace the tool or tools at no extra cost to the Owner.

G. Upon completion and before final acceptance of the work, the Trade Contractor shall remove from the site of the work and property of the Owner, all machinery, equipment, surplus materials, rubbish, barricades, signs and temporary structures and shall leave the premises in a condition which is satisfactory to the Owner.

H. The Trade Contractor shall keep one record set of the contract documents annotated to show all changes made during construction.

I. The Trade Contractor shall be responsible for the acts and omissions of all his employees and all subcontractors, their agents and employees and all other persons performing any of the work under a contract with the Trade Contractor.

J. Upon completion of the work, the Trade Contractor shall, at his or its expense, remove from the vicinity of the work, all plant, buildings, rubbish, unused materials, concrete forms and other like material, belonging to him or used under his direction during construction, and in the event of his failure to do so, the same may be removed by the Owner and the Trade Contractor, his Surety or Sureties, shall be liable for the cost thereof. Also during the construction of the work, the site, partially

finished structures, and material stockpiles shall be kept in a reasonable state of order and cleanliness.

Section 12. Changes in the Work.

A. CHANGES. Changes in the Work may be accomplished after execution of the Contract, and without invalidating the Contract, only by Change Order, Construction Change Directive, or Order for a Minor Change in the Work, subject to the limitations stated in this Article 7 and elsewhere in the Contract Documents.

1. A Change Order shall be based upon agreement among the Owner, Contractor, and Engineer; a Construction Change Directive requires agreement by the Owner and Engineer and may or may not be agreed to by the Contractor; an Order for a Minor Change in the Work may be issued by the Engineer alone.

2. Changes in the Work shall be performed under applicable provisions of the Contract Documents, and the Contractor shall proceed promptly, unless otherwise provided in the Change Order, Construction Change Directive, or Order for a Minor Change in the Work.

3. If unit prices are stated in the Contract Documents or subsequently agreed upon, and if the quantities originally contemplated are so changed in a proposed Change Order or Construction Change Directive that application of such unit prices to the quantities of work proposed will cause substantial inequity to the Owner or the Contractor, the applicable unit prices shall be equitably adjusted; provided however, that Owner may increase the number of units without change in the unit price if reasonable.

B. CHANGE ORDERS. The Contract Sum and the Contract Time may be changed only by Change Order. Methods used in determining adjustments to the Contract Sum may include those listed in Subsection C below. A Change Order is a written order to the Contractor, signed by the Contractor, the Owner and the Engineer, stating their agreement upon all of the following:

1. A change in the Work;
2. The amount of the adjustment in the Contract Sum, if any; and
3. The extent of the adjustment in the Contract Time, if any.

C. CONSTRUCTION CHANGE DIRECTIVES. A Construction Change Directive is a written order directed to the Contractor and signed by the Owner and Engineer, directing a change in the Work and stating a proposed basis for adjustment, if any, in the Contract Sum or Contract Time, or both. The Owner may by Construction Change Directive, without invalidating the Contract, order changes in the Work within the general scope of the Contract consisting of additions, deletions, or other revisions, the Contract Sum and Contract Time being adjusted accordingly.

1. A Construction Change Directive shall be used in the absence of total agreement on the terms of a Change Order.

2. If the Construction Change Directive provides for an adjustment to the Contract Sum, the adjustment shall be based on one of the following methods:

- a. By mutual acceptance of a lump sum properly itemized and supported by sufficient substantiating data to permit evaluation;
- b. By unit prices stated in the Contract Documents or subsequently agreed upon;

- c. By cost to be determined in a manner agreed upon by the parties and a mutually acceptable fixed or percentage fee; or
- d. By the method provided in Subparagraph (C)(3)(5).

3. Upon receipt of a Construction Change Directive, the Contractor shall promptly proceed with the change in the work involved and advise the Engineer and Owner of the Contractor's agreement or disagreement with the method, if any, provided in the Construction Change Directive for determining the proposed adjustment in the Contract Sum or Contract Time.

4. A Construction Change Directive signed by the Contractor indicates the agreement of the Contractor therewith, including adjustment in Contract Sum and Contract Time or the method for determining them. Such agreement shall be effective immediately and shall be recorded as a Change Order.

5. If the Contractor does not respond promptly to the Construction Change Directive or disagrees with the method for adjustment in the Contract Sum, the method and the adjustment shall be determined by the Engineer on the basis of reasonable expenditures and savings of those performing the work attributable to the change, including, in case of an increase in the Contract Sum, a percentage fee for overhead and profit not to exceed five percent (5%) of such work's actual cost for Contractor and ten percent (10%) of such work's actual cost to be apportioned between any and all subcontractors and sub-subcontractors. For work performed by Contractor's own forces, Contractor's mark-up shall be limited to actual cost plus a percentage fee for overhead and profit not to exceed ten percent (10%). In such case, the Contractor shall keep and present, in such form as the Engineer may prescribe, an itemized accounting of actual costs together with appropriate supporting data. For the purposes of this Subparagraph, actual costs shall be defined as and limited to the following:

- a. Costs of labor, including Social Security, old age and unemployment insurance, fringe benefits required by agreement or custom, and workers' compensation insurance;
- b. Costs of materials, supplies, and equipment, including costs of transportation, whether incorporated or consumed;
- c. Reasonable rental costs of machinery and equipment, exclusive of hand tools, obtained and used specifically for such work, whether rented from the Contractor or others; and
- d. Costs of premiums for all bonds (if any), permit fees, and sales, use or similar taxes directly attributable to such work. Actual cost does not include any item which could be deemed to be a general conditions cost or overhead, such as but not limited to, the cost of Contractor and Subcontractor supervisory personnel assigned to the Work, and field office and related expenses.

6. Pending final determination of actual cost to the Owner, amounts not in dispute may be included in applications for payment. The amount of credit to be allowed by the Contractor to the Owner for a deletion or change which results in a net decrease in the Contract Sum shall be actual net cost as confirmed by the Engineer. When both additions and credits covering related work or substitutions are involved in a change, the allowance for overhead and profit shall be figured on the basis of net increase, if any, with respect to that change.

7. If the Owner and Contractor do not agree with the adjustment in Contract Time or the method for determining it, the adjustment or the method shall be determined in accordance with Article 5 hereof.

8. When the adjustments in the Contract Sum and Contract Time are determined as provided herein, such determination shall be effective immediately and shall be recorded by preparation and execution of an appropriate Change Order.

D. MINOR CHANGES IN THE WORK

1. The Engineer will have authority to order minor changes in the Work not involving an adjustment in the Contract Sum or an extension of the Contract Time and not inconsistent with the intent of the Contract Documents. Such changes shall be affected by written order, and shall be binding on the Owner and the Contractor. The Contractor shall carry out such written orders promptly.

2. The Owner may at any time as the need arises, order changes within the scope of work without invalidating the Agreement. If such changes increase or decrease the amount due under the contract documents or in the time required for performance of the work, and equitable adjustment will be authorized by change order.

3. The Owner also may, at any time, by issuing a field order, make changes in the details of the work. The Trade Contractor shall proceed with the performance of any changes in the work so ordered by the Owner unless the Trade Contractor believes that such field order entitles him to a change in contract price or time, or both, in which event he shall give the Owner written notice thereof within ten (10) days after the receipt of the ordered change, and the Trade Contractor shall not execute such changes pending the receipt of an executed change order or further instruction from the Owner.

Section 14. Contract Documents.

In case of conflict between this Contract, the general conditions of the contract for construction, and the supplementary conditions, this Contract will govern.

**ARTICLE 4 – TRADE CONTRACTOR'S CONSTRUCTION SCHEDULE**

Section 1. Preconstruction Conference.

A preconstruction conference shall be scheduled at the time the Notice of Award is issued. The Trade Contractor, at the preconstruction conference, shall prepare and submit for the Owner's and the Engineer's review and approval a Trade Contractor's construction schedule for the Work, in such and form and detail as the Owner may require. The schedule shall not exceed time limits under the Contract Documents, shall be revised as required herein and at appropriate intervals as required by the conditions of the Work and Project, shall be related to the entire project to the extent required by the Contract Documents, and shall provide for the expeditious and practicable execution of the Work. The schedule shall indicate the proposed starting and completion dates for the various subdivisions of the Work as well as the totality of the Work. The schedule shall be updated every fourteen (14) days for submitted to Engineer with Trade Contractor's applications for payment. Each schedule shall contain a comparison of actual progress with the estimated progress for such time stated in the original schedule. If any schedule submitted sets forth a date for Substantial Completion for the Work or any phase of the Work beyond the date(s) of Substantial Completion established in the Contract (as the same may be extended as provided in the Contract Documents), the Trade Contractor shall submit to Engineer and Owner for their review and approval, a narrative description of the means and methods which Trade Contractor intends to employ to expedite the progress of the Work to ensure timely completion of the various phases of the Work as well as the totality of the



Work. To ensure such timely completion, Trade Contractor shall take all necessary action including, without limitation, increasing the number of personnel and labor on the Project and implementing overtime and double shifts. In that event, Trade Contractor shall not be entitled to an adjustment in the Contract Sum or the Schedule.

Section 2. Schedule of Submittals.

The Contractor shall prepare and keep current, for the Engineer's approval, a schedule of submittals which is coordinated with the Contractor's construction schedule and allows the Engineer reasonable time to review submittals.

Section 3. Conformance to Schedule.

The Contractor shall conform to the most recent schedules.

**ARTICLE 5 - TIME FOR COMPLETION AND LIQUIDATED DAMAGES**

A. The date of beginning and the time for completion of the work are essential conditions of the contract documents and the work embraced shall be commenced on a date specified in the notice to proceed.

B. The Trade Contractor shall proceed with the work at such rate of progress to insure full completion within the Contract Time. It is expressly understood and agreed, by and between the Trade Contractor and the Owner, that the contract time for the completion of the work described herein is a reasonable time, If Trade Contractor is delayed in the progress of the Work by fire, unusual delay in transportation, unanticipated adverse weather conditions, or other unavoidable casualties beyond Trade Contractor's control other than unanticipated adverse weather conditions, the Contract Time shall be extended for a reasonable period of time. "Weather" means precipitation, temperature, or wind, and an "adverse weather condition" means weather that on any calendar day varies from the average weather conditions for that day by more one hundred percent (100%) as measured by the National Oceanic and Atmospheric Administration. The term "unanticipated adverse weather conditions" means the number of days in excess of the anticipated adverse weather days per month as set forth below:

MONTHLY ANTICIPATED ADVERSE WEATHER DAYS											
JAN	FEB	MAR	APR	MAY	JUN	JUL	AUG	SEP	OCT	NOV	DEC
7	4	4	4	6	3	4	2	3	3	2	5

*By reason of example only*, if in March there are two (2) days when the snowfall exceeds the average snowfall for that day by one hundred percent (100%), those two (2) days will have experienced an adverse weather condition. However, there will have been no unanticipated adverse weather condition in March, because there are four (4) anticipated adverse weather days in March, which should be accounted for in the schedule. If, however, there are five (5) days in which the snowfall exceeds the average snowfall by one hundred percent (100%), an unanticipated adverse weather condition will have occurred, and Trade Contractor shall be entitled to request an extension of time.

C. If the Trade Contractor shall fail to complete the work within the Contract Time, or extension of time granted by the Owner, then the Trade Contractor shall pay to the Owner the amount of liquidated damages and not as penalty the sum of (\$ ) for each calendar day that the Trade Contractor shall be in default after the time stipulated in the contract documents.

D. The Owner will charge the Trade Contractor, and may deduct from the partial and final payment for the work, all architectural, engineering and construction management expenses incurred by the Owner in connection with any work accomplished after the specified completion date.

E. The Trade Contractor will not be charged with liquidated damages or any excess cost when the delay in completion of the work is due to the following, and the Trade Contractor has promptly given written notice of such delay to the Owner.

1. To any preference, priority or allocation order duly issued by the Owner.
2. To unforeseeable causes beyond the control and without the fault or negligence of the Trade Contractor, including, but not restricted to, unforeseen conditions, acts of God, or of the public enemy, acts of the Owner, fires, floods, epidemics, quarantine restrictions, strikes, freight embargoes, and abnormal and unforeseeable weather; and
3. To any delays of subcontractors occasioned by any of the causes specified in subparagraphs 1 and 2 of this paragraph E.

F. The Trade Contractor waives any right of recovery or reimbursement or by whatever name, as against the Owner or the Engineer, as a result of any delay or increase on overhead cost incurred by the Trade Contractor's association with any action or inaction on the part of any other trade contractor or supplier.

G. Any request for extension of the Contract Time shall be made in writing to the Project Manager not more than seven (7) days after commencement of the delay; otherwise it shall be waived. Any such request shall contain an estimate of the probable effect of such delay on the progress of the Work.

H. In strict accordance with C.R.S. § 24-91-103.5, the City shall not amend the Contract Price to provide for additional compensation for any delays in performance which are not the result of acts or omissions of the City or persons acting on behalf of the City.

## **ARTICLE 6 - CONTRACT SUM**

### **Section 1. Monthly or Progress Payments.**

A. The City Council of the City of Northglenn has appropriated the money necessary to fund this project. The Owner shall pay the Trade Contractor in current funds for the performance of the work, subject to any additions and deletions, by written change order, the total sum not to exceed (\$ ) (the "Original Contract Amount"). Notwithstanding anything to the contrary contained in this Agreement, no change order or other form of directive by the Owner requiring additional compensable work to be performed, which causes the aggregate amount payable under this Agreement, to exceed the amount appropriated for the Original Contract Amount, unless the Trade Contractor is given written assurance by the City of Northglenn that lawful appropriations have been made by the City Council of the City of Northglenn to cover the cost of the additional work.

B. The Engineer has, by separate agreement with the Owner, agreed to include in its monthly work estimate to the Owner, a review of the Trade Contractor's estimates of the value of all work, labor, and materials of the Trade Contractor incorporated into the Project. The Trade Contractor hereby agrees that estimates provided to the Engineer for review for the Owner shall be for work actually performed upon the project and that all such work, including labor and materials, have been paid. The determination of the amount of work completed on each application for payment by the Trade Contractor shall be made by the Engineer and shall thereafter be subject to approval by the Owner. Such determination, however, by the Engineer or approval by the Owner shall not be construed as acceptance of the work.

1. Before the first application for payment, the Trade Contractor shall submit to the Engineer and Owner a schedule of values to be allocated to the various portions of the Work, which in the aggregate equals the total Contract Sum, divided so as to facilitate

payments to subcontractors, supported by such evidence of correctness as the Engineer may direct. This schedule, when approved by the Engineer, shall be used to monitor the progress of the Work and as a basis for making progress payments hereunder. Application for monthly progress payments shall be made in writing in accordance with this Contract and shall be submitted on approved forms provided by the Owner and shall be submitted to the Owner on or before the twentieth (20th) day of each month. Applications received on time will be paid on the twentieth (20th) day of the following month, providing that the Owner approves such recommendations of the Engineer. Applications received after the twentieth (20th) day of each month shall be paid after the Owner's next pay period.

2. Pursuant to Colo. Rev. Stat. § 24-91-103, as may be amended, where the Original Contract Amount exceeds one hundred fifty thousand dollars (\$150,000.00), the Owner may retain up to five percent (5%) of the calculated value of completed work from each progress payment up until the contract is completed satisfactorily and finally accepted by the Owner. If the Owner finds satisfactory progress is being made in any phase of the contract, the Trade Contractor may make written request of the Owner for final payment of the withheld percentage. The Owner may agree to final payment of the withheld percentage if the Owner finds satisfactory and substantial reasons exist for the payment. The Trade Contractor must provide written approval to the Owner from any surety furnishing bonds for the contract work in order to receive said payment of the withheld percentage.

3. Upon receipt of written notice from the Trade Contractor that his work is ready for final inspection and acceptance by the Owner and upon receipt of final application for payment, the Owner will promptly make such final field review subject to the final payment requirements contained in Colo. Rev. Stat. § 38-26-107, as amended. If the Owner finds that the work is acceptable under the contract documents, he will recommend to the Owner that a final certificate of payment be issued. Neither final payment nor the remaining retention shall become due until the Trade Contractor submits to the Engineer an affidavit that all payrolls, bills for materials and equipment, and other indebtedness connected with the work, have been paid or otherwise satisfied. Likewise, final payment shall not be made until the consent of the surety to final payment has been obtained, and if required by the Owner, such other data establishing payment or satisfaction of all obligations, including releases, final lien waivers, and receipts and warranties, if any, have been provided to the Engineer for the use and benefit of the Owner. Should any subcontractor of the Trade Contractor or supplier of said Trade Contractor refuse to furnish any warranty and/or release or waiver, the Owner in its sole discretion, may refuse to certify final payment. The Trade Contractor may then furnish sufficient bonds satisfactory to the Owner to indemnify the Owner against any such liens.

4. Notwithstanding anything else to the contrary contained herein, such final payment by the Owner shall not be construed as a waiver of any claims affecting or arising from:

- a. Unsettled liens;
- b. Faulty or defective work appearing after substantial completion;
- c. Failure of the work to comply with the requirements of the contract documents;
- d. Terms of any special warranties required by the contract documents.

5. The acceptance by the Trade Contractor of final payment shall be and shall operate as a release to the Owner from all claims and all liability to the Trade Contractor for all things done or furnished in connection with this work and for every act and neglect of the Owner and others relating to or arising out of the work other than claims in stated amounts as may be specifically expected by the Trade Contractor with the consent of the Owner. Any

payment, however, final or otherwise, will not release the Trade Contractor or his sureties from any obligations under the contract documents or the performance bond and labor and material payment bond.

### **ARTICLE 7 - CORRECTION OF WORK**

A. During the life of the Contract and for a period of two (2) years after final acceptance, the Trade Contractor shall promptly remove from the premises all work rejected by the Owner for failure to comply with the contract documents, whether incorporated in the construction or not, and the Trade Contractor shall promptly replace and re-execute the work in accordance with the contract documents and without expense to the Owner and shall bear the expense of making good all work of other trade contractors destroyed or damaged by such removal or replacement. The Owner, however, may at its discretion elect to accept an equitable reduction in price or a refund instead of correction of the condemned work.

B. All removal and replacement work shall be done at the Trade Contractor's expense. If the Trade Contractor does not take action to remove such rejected work within ten (10) days after receipt of written notice, the Owner may remove such work and store the materials all at the expense of the Trade Contractor.

### **ARTICLE 8 - TEMPORARY FACILITIES AND SERVICES**

Unless otherwise provided in this Contract, the Trade Contractor shall furnish and make available, at no cost, all temporary facilities, including all power needed for heating and protection of facilities and work. It is the expressed intent of the parties that the Trade Contractor shall be responsible for and at its sole cost all heating and protection of facilities and work.

### **ARTICLE 9 - INDEMNIFICATION AND INSURANCE**

#### **Section 1. Indemnification.**

The Contractor, to the fullest extent permitted by law, shall defend, indemnify and hold harmless the City, its officers, employees, agents and their insurers, from and against all liability, claims and demands on account of injury, loss or damage, including without limitation, claims arising from bodily injury, personal injury, sickness, disease, death, property loss or damage or any other loss of any kind whatsoever, which arises out of or is in any manner connected with this Contract, to the extent that such injury, loss or damage is attributable to the act, omission, error, professional error, mistake, negligence or other fault of the Contractor, the Contractor's employees, subcontractors or anyone else employed directly or indirectly by the Contractor, Contractor's employees or subcontractor.

The Contractor, to the fullest extent permitted by law, shall defend, investigate, handle, respond and provide defense for and defend against any such liability, claims or demands at the sole expense of the Contractor, or at the option of the City, Contractor agrees to pay the City or reimburse the City for defense costs incurred by the City in connection with any such liability, claims, or demands. The Contractor, to the fullest extent permitted by law, shall defend and bear all other costs and expenses related thereto, including court costs and attorney fees, whether or not such liability, claims or demands alleged are groundless, false or fraudulent.

This indemnification provision is intended to comply with C.R.S. § 13-21-111.5(6), as amended, and shall be read as broadly as permitted to satisfy that intent.

#### **Section 2. Insurance.**

A. The Contractor agrees to obtain and maintain during the life of this Contract, a policy

or policies of insurance against all liability, claims, demands and other obligations assumed by the Contractor pursuant to Section 1 above. Such insurance shall be in addition to any other insurance requirements imposed by this Contract or by law. The Contractor shall not be relieved of any liability, claims, demands, or other obligations assumed pursuant to Section 1 above, by reason of its failure to obtain and maintain during the life of this Contract insurance in sufficient amounts, durations, or types.

B. Contractor shall obtain and maintain during the life of this Contract, and shall cause any subcontractor to obtain and maintain during the life of this Contract, the minimum insurance coverages listed below. Such coverages shall be obtained and maintained with forms and insurers acceptable to the City. All coverages shall be continuously maintained to cover all liability, claims, demands and other obligations assumed by the Contractor pursuant to Section 1 above. In the case of any claims-made policy, the necessary retroactive dates and extended reporting periods shall be procured to maintain such continuous coverage.

1. Worker's Compensation Insurance to cover obligations imposed by applicable law for any employee engaged in the performance of the work under this Contract, and Employers Liability Insurance with minimum limits of five hundred thousand dollars (\$500,000) each incident, five hundred thousand dollars (\$500,000) disease—policy limit, and five hundred thousand dollars (\$500,000) disease—each employee.

2. General Public Liability Insurance to be written with a limit of liability of not less than one million dollars (\$1,000,000) for all damages arising out of bodily injury, personal injury (including coverage for employee and contractual acts), including death, at any time resulting therefrom, sustained by any one person and not less than two million dollars (\$2,000,000) for all damages arising out of bodily injury, including death, at any time resulting therefrom, sustained by two or more persons in any one accident. This policy shall also include coverage for blanket contractual and independent contractor risks. The limits of General Public Liability Insurance for broad form property damage (including products and completed operations) shall be not less than one million dollars (\$1,000,000) for all damages arising out of injury to or destruction of property in any one (1) accident and not less than two million dollars (\$2,000,000) for all damages arising out of injury to, or destruction of property, including the City's property, during the policy period. The General Public Liability Insurance policy shall include coverage for explosion, collapse and underground hazards. The policy shall contain a severability of interests provision.

3. Protective Liability and Property Damage insurance covering the liability of the Owner, including any employee, officer or agent of the Owner with respect to all operations under the Contract by the Trade Contractor or his sub-contractors shall be obtained and maintained during the life of the contract. The limits of the Owner's Protective Liability Policy, to be provided by the Trade Contractor, as described in this Section 2, shall be increased to the same limits as described above for the Trade Contractor's General Public Liability Insurance.

4. Comprehensive Automobile Liability Insurance with minimum combined single limits for bodily injury and property damage of not less than one million dollars (\$1,000,000) each occurrence and one million dollars (\$1,000,000) aggregate with respect to each of the Trade Contractor's owned, hired, and non-owned vehicles assigned to or used in performance of the services. The policy shall contain a severability of interests provision. If the Trade Contractor has no owned automobiles, the requirements of this paragraph shall be met by each employee of the Trade Contractor providing services to the Owner under this contract.

C. To the extent that liability results from the acts or omissions of the Trade Contractor, all Insurance Policies and Certificates of Insurance issued for this project shall name as additional

insured(s), the Owner, whether private or governmental, the Owner's officers and employees, and the Engineer and its agents and employees, and any other person(s), company(ies), or entity(ies) deemed necessary by the Owner. The Trade Contractor shall be solely responsible for any deductible losses under any policy required herein.

D. The insurance provided by the Trade Contractor shall be primary to insurance carried by the Owner, the Engineer, and all other additional insureds, and the principal defense of any claims resulting from the Trade Contractor's obligations under the Contract shall rest with the Trade Contractor's Insurer.

**Section 3. Certificates of Insurance.**

A. The certificate of insurance provided by the Trade Contractor shall be completed by the Trade Contractor's insurance agent as evidence that policies providing the required coverages, conditions, and minimum limits are in full force and effect, and shall be reviewed and approved by the Owner prior to commencement of the contract. No other form of certificate shall be used. The certificate shall identify this Contract and shall provide that the coverages afforded under the policies shall not be cancelled, terminated or materially changed until at least thirty (30) days prior written notice has been given to the Owner. The completed certificate of insurance shall be sent to:

City of Northglenn  
Att: Kathy Kvasnicka  
11701 Community Center Drive  
Northglenn, Colorado 80233-8061

B. Failure on the part of the Trade Contractor to procure or maintain policies providing the required coverages, conditions, and minimum limits shall constitute a material breach of contract upon which the Owner may immediately terminate this contract, or at its discretion the Owner may procure or renew any such policy or any extended reporting period thereto and may pay any and all premiums in connection therewith, and all monies so paid by the Owner shall be repaid by the Trade Contractor to the Owner upon demand, or the Owner may offset the cost of the premiums against any monies due to the Trade Contractor from the Owner.

C. The Owner reserves the right to request and receive a certified copy of any policy and any endorsement thereto.

D. The parties hereto understand and agree that the Owner is relying on, and does not waive or intend to waive by any provision of this contract, the monetary limitations (presently three hundred fifty thousand dollars (\$350,000) per person and nine hundred ninety thousand dollars (\$990,000) per occurrence) or any other rights, immunities, and protections provided by the Colorado Governmental Immunity Act, 24-10-114 et seq. C.R.S., as from time to time amended, or otherwise available to the Owner, its officers or employees.

**ARTICLE 10 - PERFORMANCE, LABOR AND MATERIAL PAYMENT BONDS**

The Trade Contractor shall within ten (10) days after the receipt of a notice of award, furnish the Owner with a performance bond and a payment bond in penal sums equal to the amount of the contract price, conditioned upon the performance by the Trade Contractor of all undertakings, covenants, terms, conditions and agreements of the contract documents, and upon the prompt payment by the Trade Contractor to all persons supplying labor and materials in the prosecution of the work provided by the contract documents. Such bonds shall be executed by the Trade Contractor and a corporate bonding company licensed to transact such business in the state in which the work is to be performed and named on the current list of "Surety Companies Acceptable on Federal Bonds" as published in the Treasury Department Circular Number 570. The expense of these bonds shall be borne by the Trade Contractor. If at any time a surety on any such bond is declared a

bankrupt or loses its right to do business in the state in which the work is to be performed or is removed from the list of Surety Companies accepted on Federal Bonds, the Trade Contractor shall within ten (10) days after notice from the Owner to do so, substitute an acceptable bond (or bonds) in such form and sum and signed by such other surety or sureties as may be satisfactory to the Owner. The premiums on such bond shall be paid by the Trade Contractor. No further payments will be deemed due nor shall be made until the new surety or sureties shall have furnished an acceptable bond to the Owner.

### **ARTICLE 11 – CLAIMS AND DISPUTES**

A. Definition. A claim is a demand or assertion by one of the parties seeking, as a matter of right, adjustment of contract terms, payment of money, extension of time, or other relief with respect to the terms of the Contract. The term “claim” also includes other disputes between the Owner and Contractor arising out of or relating to the Contract. Claims must be made by written notice. The responsibility to substantiate claims shall rest with the party making the claim.

B. Decision of Engineer or Architect. Claims may, upon request of both the Contractor and the Owner, be referred initially to the Engineer or Architect for action as provided in Article 3, Section 12.

C. Time limits on Claims. Claims by either party must be made within twenty one (21) days after occurrence of the event giving rise to such claim or within twenty one (21) days after the claimant first recognizes, or reasonably should have recognized, the condition giving rise to the claim, whichever is later. An additional claim made after the initial claim has been implemented by change order will not be considered unless submitted in a timely manner.

D. Continuing Contract Performance. Pending final resolution of a claim, including litigation, unless otherwise directed by Owner in writing, the Contractor shall proceed diligently with performance of the Contract and the Owner shall continue to make payments in accordance with the Contract Documents.

E. Waiver of Claims: Final Payment. The making of Final Payment shall constitute a waiver of claims by the Owner except those arising from:

1. Liens, claims, security interests, or encumbrances arising out of the Contract and unsettled;
2. Failure of the Work to comply with the requirements of the Contract Documents;
3. Terms of special warranties required by the Contract Documents; or
4. Faulty or defective work appearing after Substantial Completion.

F. Claims for Concealed or Unknown Conditions. If conditions are encountered at the site which are (1) subsurface or otherwise concealed physical conditions which differ materially from those indicated in the Contract Documents or (2) unknown physical conditions of an unusual nature, which differ materially from those ordinarily found to exist and generally recognized as inherent in construction activities of the character provided for in the Contract Documents, then notice by the observing party shall be given to the other party promptly before conditions are disturbed and in no event later than seven (7) days after first observance of the conditions. Site conditions which an experienced and prudent contractor could have anticipated by visiting the site, familiarizing himself with the local conditions under which the Work is to be performed and correlating his observations with the requirements of the Contract Documents shall not be considered as claims for concealed or unknown conditions, nor shall the locations of utilities which differ from locations provided by the

utility companies. The Engineer or Architect will promptly investigate such conditions and, if they differ materially and cause an increase or decrease in the Contractor's cost of, or the required time for, performance of any part of the Work, will recommend an equitable adjustment in the Contract Sum or Contract Time, or both. If the Engineer or Architect determines that the conditions at the site are not materially different from those indicated in the Contract Documents and that no change in the terms of the Contract is justified, the Engineer or Architect shall so notify the Owner and Contractor in writing, stating the reasons. Claims by either party in opposition to such determination must be made within twenty-one (21) days after the Engineer or Architect has given notice of the decision. If the Owner and Contractor cannot agree on an adjustment in the Contract Sum or Contract Time, the adjustment shall be referred to the Engineer or Architect for initial determination, subject to further proceeding pursuant to these Contract Documents.

G. Claims for Additional Cost. If the Contractor wishes to make claim for an increase in the Contract Sum, written notice as provided herein shall be given before proceeding to execute the work. Said notice shall itemize all claims and shall contain sufficient detail and substantiating data to permit evaluation of same by Owner and Engineer or Architect. No such claim shall be valid unless so made. Prior notice is not required for claims relating to an emergency endangering life or property. If the Contractor believes additional cost is involved for reasons including but not limited to (1) a written interpretation from the Engineer or Architect, (2) an order by the Owner to stop the Work where the Contractor was not at fault, (3) a written order for a minor change in the Work issued by the Engineer or Architect, (4) failure of payment by the Owner, (5) termination of the Contract by the Owner, (6) Owner's suspension, or (7) other reasonable grounds, claim shall be filed in accordance with the procedure established herein Any change in the Contract Sum resulting from such claim shall be authorized by change order or construction change directive.

H. Claims for additional time. If the Contractor wishes to make claim for an increase in the Contract Time, written notice as provided herein shall be given. The Contractor's claim shall include an estimate of cost and of probable effect of delay on progress of the Work. In the case of a continuing delay, only one claim is necessary.

I. Injury or damage to person or property. Subject to the Parties' obligations and responsibilities under the Contract Documents in general and Article 8 hereof in particular, if either party to the Contract suffers injury or damage to person or property because of an act or omission of the other party, of any of the other party's employees or agents, or of others for whose acts such party is legally liable, written notice of such injury or damage, whether or not insured, shall be given to the other party within a reasonable time not exceeding ten (10) days after first observance. The notice shall provide sufficient detail to enable the other party to investigate the matter. If a claim for additional cost or time related to this claim is to be asserted, it shall be filed as provided in Article 3, Section 12.

## **ARTICLE 12 - RESOLUTION OF CLAIMS AND DISPUTES**

A. The Engineer (if the matter is referred to the Engineer for initial decision) will review claims and take one or more of the following preliminary actions within ten (10) days of receipt of a claim: (1) request additional supporting data from the claimant; (2) submit a schedule to the parties indicating when the Engineer expects to take action; (3) reject the claim in whole or in part, stating the reasons for rejection; (4) recommend approval of the claim by the other party; or (5) suggest a compromise. The Engineer may also, but is not obligated to, notify the surety, if any, of the nature and amount of the claim.

B. If a claim has been resolved, the Engineer (or at the Owner's option, Owner), will prepare or obtain appropriate documentation.

C. If a claim has not been resolved, the party making the claim shall within ten (10) days after the Engineer's preliminary response, take one or more of the following actions: (1) submit additional supporting data requested by the Engineer; (2) modify the initial claim; or (3) notify the



Engineer that the initial claim stands.

D. If a claim has not been resolved after consideration of the foregoing and of further evidence presented by the parties or requested by the Engineer, the Engineer will notify the parties in writing that the Engineer's decision will be made within seven (7) days, which decision will be considered advisory only and not binding on the parties in the event of litigation in respect of the claim. Upon expiration of such time period, the Engineer will render to the parties the Engineer's written decision relative to the claim, including any change in the Contract Sum or Contract Time or both. If there is a surety and there appears to be a possibility of a Trade Contractor's default, the Engineer may, but is not obligated to, notify the surety and request the surety's assistance in resolving the controversy.

E. The dispute clause does not preclude the considerations of questions of fact or law in connection with decisions provided for in Paragraph A above. Nothing in this Agreement, however, shall be construed as making final a decision of an administrative official, representative or City Council on a question of fact or law.

F. As between the parties of this Agreement, as to all acts or failure to act by either party of this Agreement, any applicable statute of limitation shall commence to run from the date of the agreed party's discovery of such act or failure to act.

G. The Trade Contractor shall give written notice to the Owner within ten (10) days of any dispute/claim arising under this Contract upon which the Trade Contractor seeks compensation or change of contract documents, otherwise the Trade Contractor's dispute/claim shall be deemed waived. Said ten (10) days written notice shall not be deemed to run from the date of discovery in this instance but from the date the dispute/claim has arisen.

### **ARTICLE 13- TERMINATION**

A. This Agreement may be terminated in whole or in part in writing by either party in the event of substantial failure by the other party to fulfill its obligations under this Agreement through no fault of the terminating party; provided that no such termination may be effected unless the other party is given (1) not less than ten (10) days written notice (delivered by certified mail, return receipt requested) of intent to terminate; and (2) an opportunity for consultation with the terminating party prior to termination.

B. This Agreement may be suspended or terminated in whole or in part, in writing, by the Owner for its convenience; provided that no such termination may be effected unless the Trade Contractor is given (1) not less than ten (10) days written notice (delivered by certified mail, return receipt requested) of intent to suspend or terminate; and (2) an opportunity for consultation with the Owner prior to suspension or termination.

C. Suspension for Convenience: The Owner, for its own convenience, may suspend the contract in whole or in part at any time by written notice to the Trade Contractor. Such notice shall state the extent and the effective date of such suspension, and on the effective date thereof the Trade Contractor shall promptly suspend such work to the extent specified, and during the period of such suspension shall properly care for and protect all work and materials, housing and equipment on hand for construction under the contract. The Trade Contractor also shall promptly supply the Owner with copies of all outstanding orders for materials, equipment and services, and shall take such action relative to such orders as may be directed by the Owner. If the performance of the work is thus suspended, the Trade Contractor shall be entitled to be reimbursed for all additional expense incurred by reason of such suspension as agreed upon by the Trade Contractor and the Owner.

D. Termination for Convenience:

1. The Owner may for its own convenience terminate work under the contract in whole or in part at any time by written notice to the Trade Contractor. Such notice shall state the extent and effective date of such termination and on the effective date thereof, the Trade Contractor will, and as to the extent directed, stop work under the contract and the placement of further orders of subcontracts under the contract, terminate work under order and subcontracts under the contract, and take any necessary action to protect property in the Trade Contractor's possession in which the Owner has or may acquire an interest.

2. In the event of such termination, the Owner shall pay to the Trade Contractor: (1) its direct costs (excluding overhead) for all work done in conformity with the Contract to the effective date of such termination and (2) other costs pertaining to the work which the Trade Contractor may incur as a result of such termination, all as approved by the Owner plus ten percent (10%) of such costs (excluding costs under (2) above) for overhead and profit, provided, however, that in no event shall the total amount to be paid under this Article 11, Section D.(2) plus payments previously made, exceed the lesser of (a) the total aggregate contract price specified in the Trade Contract; or (b) that proportion of the aggregate total contract price specified in the date of termination bears to the entire work to be performed hereunder. Any payment under this Article 11, Section D.(2) shall be made upon the expiration of the period within which liens may be filed under the laws of the state of Colorado, subject, however, to withholding by the Owner for the reasons and in the manner provided in those provisions pertaining to withholding of payments for liens.

E. Termination for Default:

1. The Owner shall have the right to terminate the employment of the Trade Contractor after giving ten (10) days written notice of the termination to the Trade Contractor in the event of any default by the Trade Contractor. In the event of such termination, the Owner may take possession of the work and of all materials, tools and equipment thereon and may finish the work by whatever method and means he may select. It shall be considered a default by the Trade Contractor whenever he shall:

- a. Disregard or violate important provisions of the contract documents or the Owner's instructions, or fail to prosecute the work according to the agreement schedule of completion, including extensions thereof;
- b. Fail to provide a qualified representative, competent workmen or subcontractors, or proper materials, or fail to make prompt payment therefor; and
- c. Fail to submit a completion schedule within fourteen (14) days after award of contract.

2. Upon termination of the contract by the Owner for default by the Trade Contractor, no further payments shall be due to the Trade Contractor until the work is completed. If the unpaid balance of the contract amount shall exceed the cost of completing the work including all overhead costs, the excess shall be paid to the Trade Contractor. If the cost of completing the work shall exceed the unpaid balance, the Trade Contractor shall pay the difference to the Owner. The amount of the cost incurred by the Owner in implementing the work, and the damage incurred through the Trade Contractor's default, shall be approved by the Owner.

3. The provisions of this Article 11, Section D.(2) shall not apply in the event of default of the Trade Contractor; provided, however, that the provisions of Article 11, Section D.(2) shall apply in the event of substantial failure by the Owner to fulfill its obligations under this Agreement.

**ARTICLE 14 - SIMULTANEOUS WORK BY OTHERS**

A. The Owner reserves the right to let other contracts in connection with this project. The Trade Contractor shall afford other trade contractors reasonable opportunity for the introduction and storage of their materials and the execution of their work, and shall properly connect and coordinate his work with theirs.

B. If the proper execution or results of any part of the Trade Contractor's work depends upon the work of any other trade contractor, the Trade Contractor shall inspect and promptly report to the Engineer any defects in such work that render it unsuitable for such proper execution and results. Failure of the Trade Contractor to so inspect and report defects shall constitute an acceptance of the other trade contractors' work as fit and proper for the addition of his work thereto, except as to defects which may develop in the other trade contractors' work after the execution of his work.

C. The Trade Contractor shall coordinate his operations with those of other trade contractors. Cooperation will be required in the arrangement for the storage of materials and in the detailed execution of the work.

D. The Trade Contractor, including his subcontractors, shall keep informed of the progress and the detail work of other trade contractors and shall notify the Engineer immediately of lack of progress, defective workmanship, or lack of coordination on the part of other trade contractors. Failure of the Trade Contractor to keep informed of the work progressing on the site and failure to give notice of lack of progress, defective workmanship, or lack of coordination by others shall be construed as acceptance by him of the work and the status of work as being satisfactory for proper execution of his own work.

E. All materials and labor shall be furnished at such times as shall be for the best interest of all trade contractors concerned, to the end that the combined work of all may be properly and fully completed on contract time.

F. Nothing herein shall be construed in any way as giving the Trade Contractor a claim as against the Owner and the Engineer resulting in any revised schedule based upon delay caused by any other trade contractor or supplier.

**ARTICLE 15 - SUBCONTRACTING**

A. The Trade Contractor may utilize the services of specialty subcontractors on those parts of the work which, under normal contracting practices, are performed by specialty subcontractors.

B. Before execution of the contract, the Trade Contractor shall submit the names of all subcontractors, including contact persons, phone numbers, and addresses to the Engineer or Architect and Owner. The Trade Contractor shall also promptly notify all parties of any changes in subcontractors or subcontractor contact information.

C. The Trade Contractor shall be fully responsible to the Owner for the acts and omissions of his subcontractors, and of persons either directly or indirectly employed by them, as he is for the acts and omissions of persons directly employed by him.

D. The Trade Contractor shall cause appropriate provisions to be inserted in all subcontracts relative to the work to bind subcontractors to the Trade Contractor by the terms of the contract documents insofar as applicable to the work of subcontractors and to give the Trade Contractor the same power as regards terminating any subcontract that the Owner may exercise over the Trade Contractor under any provision of the contract documents.

E. Nothing contained in this Contract will create any contractual relation between any subcontractor and the Owner.

#### **ARTICLE 16 - GUARANTY**

A. The Trade Contractor shall guarantee all materials and equipment furnished and work performed for a period of two (2) years from the date of final acceptance of the contract by the Owner that the work is free from all defects due to faulty materials or workmanship and that the Trade Contractor shall promptly make such corrections as may be necessary by reason of such defects including the repairs of any damage to other parts of the system resulting from such defects. The Owner will give notice of observed defects with reasonable promptness. In the event that the Trade Contractor should fail to make such repairs, adjustments, or other work that may be made necessary by such defects, the Owner may do so and charge the Trade Contractor the cost thereby incurred. The performance bond shall remain in full force and effect through the guarantee period.

B. Whenever in the specifications a guarantee or maintenance bond is required to be furnished for any item of equipment, material or portion of the work, such guarantee shall be submitted to the Owner and a written approval will be issued to the Trade Contractor before any such equipment, material or construction is ordered and incorporated in work by the Trade Contractor.

#### **ARTICLE 17 - SALES TAX**

The Trade Contractor and all of his subcontractors must make application to the Colorado State Department of Revenue for a certificate of exemption to permit the purchase of building materials for the construction of this project without payment of the sales tax. Prior to the start of construction, the Trade Contractor shall furnish copies of such certificates to the Owner. Applications and certificates must be on forms provided by the Department of Revenue.

#### **ARTICLE 18 - MISCELLANEOUS PROVISIONS**

A. This Agreement is made and entered into subject and conformable to the laws of the State of Colorado and the Home Rule Charter of the City of Northglenn. To the extent any provision hereof is inconsistent with said laws and Charter, said laws and Charter shall control.

B. The Trade Contractor shall comply with all federal and state laws and local ordinances and regulations which affect those engaged or employed in the work or which affect the conduct of the work, and of all such orders and decrees of bodies or tribunals having any jurisdiction or authority over the same, and shall at all times observe and comply with all such existing laws, ordinances, regulations and decrees, and shall protect and indemnify the Owner and the Engineer against any claim or liabilities arising solely from or based solely on the violations of such law, ordinance, regulation, order or decree, whether by itself, its subconsultants, agents, or employees.

C. The Trade Contractor will take affirmative action to not discriminate against any employee or applicant for employment because of race, creed, color, national origin, sex or handicap, if otherwise qualified.

D. In the event any provision of this Agreement is held invalid and unenforceable, the remaining provisions shall be valid and binding upon the parties.

E. One or more waivers by either party of any provision, term, condition or covenant shall not be construed by the other party as a waiver of a subsequent breach of the same by the other party.

F. The Owner and the Trade Contractor each binds itself and its partners, successors,

executors, administrators, and assigns to this Agreement. Neither the Owner nor the Trade Contractor will assign, sublet, or transfer its interest in this Agreement without the written consent of the other.

G. Nothing herein shall be construed as creating any personal liability on the part of any officer or agent of any public body which may be a party hereto, nor shall it be construed as giving any rights or benefits hereunder to anyone other than the Owner and the Trade Contractor.

H. Keep Jobs in Colorado Act: Pursuant to the Keep Jobs in Colorado Act, C.R.S. 8-17-101 *et seq.* (the "Act") and the rules adopted by the Division of Labor of the Colorado Department of Labor and Employment implementing the Act (the "Rules"), the Contractor shall employ Colorado labor to perform at least eighty percent (80%) of the work and shall obtain and maintain the records required by the Act and the Rules. For purposes of this Section "Colorado labor" means any person who is a resident of the state of Colorado at the time of this Project, without discrimination as to race, color, creed, sex, sexual orientation, marital status, national origin, ancestry, age, or religion except when sex or age is a bona fide qualification. A resident of the state is a person who can provide a valid Colorado driver's license, a valid Colorado state-issued photo identification, or documentation that he or she has resided in Colorado for the last thirty (30) days. Contractor represents that it is familiar with the requirements of the Act and the Rules and will fully comply with same. This Section shall not apply to any project for which appropriation or expenditure of moneys may be reasonably expected not to exceed five hundred thousand dollars (\$500,000) in the aggregate for any fiscal year.

#### **ARTICLE 19 - ATTACHMENTS, SCHEDULES AND SIGNATURES**

It is further mutually agreed that this Agreement and the contract documents constitute the entire Agreement between the Owner and the Trade Contractor and supersede all prior or oral understandings. This Agreement may only be amended, supplemented, modified, or cancelled by a duly executed written amendment.

IN WITNESS WHEREOF the parties hereto each herewith subscribe the same in triplicate.

**CITY OF NORTHGLENN, COLORADO**

By: \_\_\_\_\_

Name: \_\_\_\_\_

Title: Mayor

ATTEST:

\_\_\_\_\_  
Johanna Small, CMC, City Clerk

APPROVED AS TO FORM:

\_\_\_\_\_  
Corey Y. Hoffmann, City Attorney

**TRADE CONTRACTOR**

By: \_\_\_\_\_

Name: \_\_\_\_\_

Title: \_\_\_\_\_

STATE OF COLORADO    )  
                                  ) ss.  
COUNTY OF \_\_\_\_\_ )

The foregoing instrument was acknowledged before me this \_\_\_\_\_ day of \_\_\_\_\_,  
20\_\_ by \_\_\_\_\_, as \_\_\_\_\_ of  
\_\_\_\_\_.

My commission expires: \_\_\_\_\_

Witness my hand and official seal.

\_\_\_\_\_  
Notary Public



City of Northglenn  
11701 Community Center Drive  
Northglenn, Colorado 80233

## BOND FORM

### PERFORMANCE, PAYMENT, MAINTENANCE AND WARRANTY BOND

KNOWN ALL MEN BY THESE PRESENTS, that \_\_\_\_\_, as Principal, herein called Contractor, and \_\_\_\_\_, as surety, herein called Surety, are hereby held and firmly bound unto the **City of Northglenn**, as Obligee, herein called the Owner, the amount of \_\_\_\_\_ Dollars (\$\_\_\_\_\_) for the payment whereof Contractor and Surety find themselves their heirs, executors, administrators, successors, and assigns, jointly and severally, firmly by these presents.

WHEREAS, Contractor has by written Agreement dated \_\_\_\_\_, 20\_\_\_\_, entered into a Contract with the Owner for the \_\_\_\_\_.

Project Number \_\_\_\_\_ in accordance with Plans and Specifications prepared by \_\_\_\_\_ which Contract is by reference made a part hereof, and is herein referred to as the Contract.

WHEREAS, Contractor and Surety are jointly and severally liable under the provisions hereof and action against either or both may proceed without prior action against the other, and both may be jointed in one action.

WHEREAS, the Surety hereby waives notice of any alteration of the Contract or extension of time made by Owner.

NOW, THEREFORE, the conditions of this obligation are as follows:

FIRST. The Contractor shall: (1) faithfully perform all requirements and obligations of the Contract, and other applicable law, and satisfy all claims and demands incurred for the same; and (2) fully indemnify and save harmless the City from all costs and damages which the City may incur in making good any default.

SECOND. To the extent permitted by law, the Contractor shall protect, defend, indemnify and save harmless the City and its officers, agents, servants and employees, from and against suits, actions, claims, losses, liability or damage of any character, and from and against costs and expenses, including, in part, attorney fees incidental to the defense of such suits, actions, claims losses, damages or liability on account of injury, disease, sickness, including death, to any person, or damage to property, including, in part, the loss of use, resulting therefrom, based upon or allegedly based upon any act, omission or occurrence of the Contractor, or his employees, servants, agents, subcontractors or suppliers, or anyone else under the Contractor's direction and control (regardless of whether or not cause in part by a party indemnified hereunder), and arising out of, occurring in connection with, resulting from, or caused by the performance or failure of performance of any Work called for by the Contract, or from conditions created by the performance or non-performance of said Work.

Whenever Contractor shall be, and declared by Owner to be in default under Contract, the Owner having performed Owner's obligations thereunder, the Surety may promptly remedy the default, or shall promptly:

1. Complete the Contract in accordance with its terms and conditions or

2. Obtain a Bid or Bids for completing the Contract in accordance with its terms and conditions, and upon determination by Surety of the lowest responsible Bidder, or if the Owner elects upon determination by the Owner and the Surety Jointly of the lowest responsible bidder, arrange form a Contract between such Bidder and Owner, and make available as Work progresses (even though there should be a default or succession of defaults under Contract or Contracts of completion arranged under this paragraph) sufficient funds to pay the cost of completion less the balance of the Contract price but not exceeding, including other costs and damages for which the Surety may be liable hereunder, the amount set forth in the first paragraph, shall mean the total amount payable by Owner to Contractor under Contract and any Contract Change Orders thereto, less the amount properly paid by Owner to Contractor.

THIRD. The Contractor shall pay all persons, firms and corporations, all just claims due them for the payment of all laborers and mechanics for labor performed, for all materials and equipment used or rented in the performance of the work covered by the Contract subject, however, to the following conditions.

1. A claimant is defined as one having a direct Contract with the Principal, or with a Subcontractor of the Principal for labor material or both, used or reasonably required for use in performance of the Contract, labor and material being construed to include that part of water, gas, power, light, heat, oil, gasoline, telephone service or rental of equipment directly applicable to the Contract.
2. The above named Principal and Surety hereby jointly and severally agree with the Owner that every claimant as herein defined, who has not been paid in full before the expiration of a period of ninety (90) days after the date on which the last of such claimant's Work or labor was done or performed, or materials were furnished by such claimant, may sue on this bond for the use of such claimant, prosecute the suit to final judgment for such sum or sums as may be due the claimant, and have execution thereon. The Owner shall not be liable for the payment of any costs or expenses of any such suit.
3. No suit or action shall be commenced hereunder by any claimant:
  - a. Unless claimant, other than one having a direct Contract with the Principal, shall have given written notice to any two of the following: the Principal, the Owner, or the Surety above named, within ninety (90) days after such claimant did or performed the last of the Work or labor, or furnished the last of the materials for which said claim is made, stating with substantial accuracy the amount claimed and the name of the party to whom the Work or labor was done or performed. Such notice shall be served by mailing same by registered mail or certified, postage prepaid, in an envelope addressed to the Principal, Owner, or Surety, at any place where an office is regularly maintained for the transaction of business, or served in any manner in which legal process may be served in the state in which the aforesaid Project is located, save that such service need not be made by a public officer.
  - b. After expiration of six (6) months following the date on which Principal ceased Work on said Contract, it being understood, however, that if any limitation embodied in this bond is prohibited by any law controlling the construction hereof such limitation shall be deemed to be amended so as to be equal to the minimum period of limitation permitted by such law.

Other than in a state court of competent jurisdiction in and for the county or other political subdivision of the state in which the Project, or any part thereof is situated, or in the United States District Court for the District in which the Project, or any part thereof, is situated, and not elsewhere.



FORTH. The Contractor and Surety shall guarantee and warrant that all Work shall remain in good order and repair for a period of **two (2) years** from date of probationary acceptance from all causes arising from defective workmanship and materials, and shall make all repairs arising from said causes during such period without further compensation, and shall guarantee the Facilities and Work and areas within the public rights-of-way affected by such Facilities in good order and repair without further compensation for a period of two (2) years from and after final acceptance thereof by the City. The determination of the necessity for the repair or replacement of any Work or Facilities shall rest entirely with the City, and the City's decision upon the matter shall be final and obligatory upon the Contractor, subject to judicial review pursuant to applicable law.

The Surety shall be deemed and held, notwithstanding any Contract provision, or other agreement to the contrary, to consent without notice to:

1. Any extension of time to the Contractor in which to perform any Work, Permit conditions or obligations.
2. Any change in the Permit or other Permit documents.

Further, the Surety shall pay to the City all costs and attorney fees necessary to enforce the provisions of the bond provisions contained herein.

Unless prohibited by law, an action on this bond may be brought by the City or any person entitled to the benefits of this bond at any time with two (2) years from the date of final acceptance of the Work performed pursuant to the Permit.

Upon full compliance with all the obligations of the Contract, the City shall release this bond, in writing. This bond shall remain in effect until released by the City or the City consents in writing to acceptance of a substitute bond.

No right of action shall accrue on this bond to or for the use of any person or corporation other than the Owner named herein or the heirs, executors, administrators or successors of the Owner.

Signed and sealed this \_\_\_\_\_ day of \_\_\_\_\_, 20 \_\_\_\_.

\_\_\_\_\_  
Witness

\_\_\_\_\_  
Contractor

\_\_\_\_\_  
Title

\_\_\_\_\_  
Title

\_\_\_\_\_  
Witness

\_\_\_\_\_  
Surety

\_\_\_\_\_  
Title

\_\_\_\_\_  
Title



City of Northglenn  
11701 Community Center Dr.  
Northglenn, CO 80233

**NOTICE OF AWARD**

TO: \_\_\_\_\_  
\_\_\_\_\_  
\_\_\_\_\_

PROJECT NAME: \_\_\_\_\_

PROJECT NUMBER: \_\_\_\_\_

PROJECT MANAGER: \_\_\_\_\_

The **City of Northglenn (CITY)** has considered the BID submitted by you for the above described work in response to its Invitation For Bid dated \_\_\_\_\_ and Instructions to Bidders.

You are hereby notified that your BID has been accepted for items in the amount of \_\_\_\_\_, and two executed Agreements were presented to the Northglenn City .

You are required by the Instructions to Bidders to furnish the required Certificate of Insurance within ten (10) calendar days from the date of this Notice to you.

You are required to return an acknowledged copy of this NOTICE OF AWARD to CITY at the attention of the Engineering Department.

Dated this \_\_\_\_\_ day of \_\_\_\_\_, 20\_\_\_\_.

**CITY of Northglenn, Colorado**

By \_\_\_\_\_

Name \_\_\_\_\_

Title \_\_\_\_\_

**ACCEPTANCE OF NOTICE**

Receipt of the above NOTICE OF AWARD is hereby acknowledged:

**CONTRACTOR:**

\_\_\_\_\_  
(Name of Contractor)

By \_\_\_\_\_

Name \_\_\_\_\_  
(Please Type or Print)

Title \_\_\_\_\_

**Consultant:**

Return one signed original to:  
City of Northglenn  
Engineering Division  
11701 Community Center Dr.  
Northglenn, CO 80233



City of Northglenn  
11701 Community Center Dr.  
Northglenn, CO 80233

**NOTICE TO PROCEED**

TO: \_\_\_\_\_  
\_\_\_\_\_  
\_\_\_\_\_

DATE: \_\_\_\_\_

PROJECT NAME: \_\_\_\_\_

PROJECT NUMBER: \_\_\_\_\_

PROJECT MANAGER: \_\_\_\_\_

You are hereby notified to commence WORK in accordance with the Agreement dated \_\_\_\_\_, 20\_\_\_\_\_, on or before \_\_\_\_\_ 20\_\_\_\_\_, and you are to complete the WORK within \_\_\_\_\_ days thereafter. The date of completion of all work is therefore \_\_\_\_\_, 20\_\_\_\_\_.

**CITY of Northglenn, Colorado**

By \_\_\_\_\_  
Name \_\_\_\_\_  
Title \_\_\_\_\_

**ACCEPTANCE OF NOTICE**

Receipt of the above NOTICE TO PROCEED is hereby acknowledged this \_\_\_\_\_ day of \_\_\_\_\_, 20\_\_\_\_\_.

**CONTRACTOR:**

\_\_\_\_\_  
(Name of Contractor)

By \_\_\_\_\_  
Name \_\_\_\_\_  
(Please Type or Print)  
Title \_\_\_\_\_

Return one signed original  
Notice To Proceed to:

City of Northglenn  
Engineering Division  
P.O. Box 330061  
Northglenn, CO 80233-8061



**Owner:** City of Northglenn  
 11701 Community Center Drive  
 Northglenn, CO 80233-8061

## Payment Application and Certification

**Project:** Project Name \_\_\_\_\_  
 Address \_\_\_\_\_  
 City, State Zip \_\_\_\_\_

**Payment Application No.:** 1 \_\_\_\_\_

**Period From:** \_\_\_\_\_

**Period To:** \_\_\_\_\_

**Project Number:** # \_\_\_\_\_

**Contract Date:** \_\_\_\_\_

**Distribution:**

Owner

Construction Manager

Project Manager

Contractor

**Contractor:** Company \_\_\_\_\_  
 Address \_\_\_\_\_  
 City, State Zip \_\_\_\_\_

**Project Manager:** Company \_\_\_\_\_

Address \_\_\_\_\_

City, State Zip \_\_\_\_\_

Application for Payment Summary			Certification for Payment	
1. Original Contract Sum		\$ -	Contractor certifies that the amount requested on this Payment Application is based on work completed in accordance with the terms of the contract for Project No. #  Contractor Signature:  By: _____ Date: _____  Amount Certified: \$ _____ -  Project Manager Signature:  By: _____ Date: _____  Construction Manager Signature:  By: _____ Date: _____  Notary Signature:  By: _____ Date: _____	
<b>2. Net Change By Change Orders</b>		<b>\$ -</b>		
a. Total changes approved in previous months				
Additions	\$ -			
Deductions	\$ -			
b. Total changes approved this month				
Additions	\$ -			
Deductions	\$ -			
3. Contract Sum To Date (Line 1 + Line 2)		\$ -		
4. Total Completed and Stored (Column G, page 2)		\$ -		
<b>5. Total Retainage</b>		<b>\$ -</b>		
a. Completed Work Retainage (Retainage for Column D + Column E, page 2)	\$ -			
b. Stored Material Retainage (Retainage for Column F, page 2)	\$ -			
6. Total Completed and Stored Less Retainage (Line 4-Line 5)		\$ -		
7. Less Previous Payment Applications (Line 6 of previous application)		\$ -		
8. Current Payment Due (Line 6 less Line 7)		\$ -		
9. Balance to Finish, Including Retainage (Line 3 less Line 6)		\$ -		



Owner: City of Northglenn  
 11701 Community Center Drive  
 Northglenn, CO 80233-8061

**Payment Application Detail Sheet**

A	B	C	D	E	F	G	H	I	J
Item No.	Description of Work	Scheduled Value	Previous Work	Work Completed This Period	Presently Stored Materials	Total Completed and Stored to Date	Percent Complete	Balance to Finish	Total Retainage
					(Not in D or E)	(D+E+F)	(G/C)	(C-G)	0%
1		\$ -	\$ -	\$ -	\$ -	\$ -	0.00%	\$ -	\$ -
2		\$ -	\$ -	\$ -	\$ -	\$ -	0.00%	\$ -	\$ -
3		\$ -	\$ -	\$ -	\$ -	\$ -	0.00%	\$ -	\$ -
4		\$ -	\$ -	\$ -	\$ -	\$ -	0.00%	\$ -	\$ -
5		\$ -	\$ -	\$ -	\$ -	\$ -	0.00%	\$ -	\$ -
6		\$ -	\$ -	\$ -	\$ -	\$ -	0.00%	\$ -	\$ -
7		\$ -	\$ -	\$ -	\$ -	\$ -	0.00%	\$ -	\$ -
8		\$ -	\$ -	\$ -	\$ -	\$ -	0.00%	\$ -	\$ -
9		\$ -	\$ -	\$ -	\$ -	\$ -	0.00%	\$ -	\$ -
10		\$ -	\$ -	\$ -	\$ -	\$ -	0.00%	\$ -	\$ -
11		\$ -	\$ -	\$ -	\$ -	\$ -	0.00%	\$ -	\$ -
12		\$ -	\$ -	\$ -	\$ -	\$ -	0.00%	\$ -	\$ -
13		\$ -	\$ -	\$ -	\$ -	\$ -	0.00%	\$ -	\$ -
14		\$ -	\$ -	\$ -	\$ -	\$ -	0.00%	\$ -	\$ -
15		\$ -	\$ -	\$ -	\$ -	\$ -	0.00%	\$ -	\$ -
16		\$ -	\$ -	\$ -	\$ -	\$ -	0.00%	\$ -	\$ -
17		\$ -	\$ -	\$ -	\$ -	\$ -	0.00%	\$ -	\$ -
18		\$ -	\$ -	\$ -	\$ -	\$ -	0.00%	\$ -	\$ -
19		\$ -	\$ -	\$ -	\$ -	\$ -	0.00%	\$ -	\$ -
20		\$ -	\$ -	\$ -	\$ -	\$ -	0.00%	\$ -	\$ -
21		\$ -	\$ -	\$ -	\$ -	\$ -	0.00%	\$ -	\$ -
22		\$ -	\$ -	\$ -	\$ -	\$ -	0.00%	\$ -	\$ -
23		\$ -	\$ -	\$ -	\$ -	\$ -	0.00%	\$ -	\$ -
24		\$ -	\$ -	\$ -	\$ -	\$ -	0.00%	\$ -	\$ -
25		\$ -	\$ -	\$ -	\$ -	\$ -	0.00%	\$ -	\$ -
26		\$ -	\$ -	\$ -	\$ -	\$ -	0.00%	\$ -	\$ -
27		\$ -	\$ -	\$ -	\$ -	\$ -	0.00%	\$ -	\$ -
28		\$ -	\$ -	\$ -	\$ -	\$ -	0.00%	\$ -	\$ -
29		\$ -	\$ -	\$ -	\$ -	\$ -	0.00%	\$ -	\$ -
30		\$ -	\$ -	\$ -	\$ -	\$ -	0.00%	\$ -	\$ -
31		\$ -	\$ -	\$ -	\$ -	\$ -	0.00%	\$ -	\$ -
32		\$ -	\$ -	\$ -	\$ -	\$ -	0.00%	\$ -	\$ -
33		\$ -	\$ -	\$ -	\$ -	\$ -	0.00%	\$ -	\$ -
34		\$ -	\$ -	\$ -	\$ -	\$ -	0.00%	\$ -	\$ -
35		\$ -	\$ -	\$ -	\$ -	\$ -	0.00%	\$ -	\$ -
36		\$ -	\$ -	\$ -	\$ -	\$ -	0.00%	\$ -	\$ -
<b>Total</b>			\$ -	\$ -	\$ -	\$ -	<b>0.00%</b>	\$ -	\$ -

<b>Project No.:</b>	<b>RFI Number:</b>
<b>Project Name:</b>	<b>Date Received:</b>
<b>Project Manager:</b>	<b>Date Required:</b>
<b>Project Engineer:</b>	<b>Forwarded To:</b>
<b>Contractor:</b>	<b>Date Responded:</b>

<b>Specification No.:</b>	<b>Page No.:</b>
check one: <input type="checkbox"/> RFI	<input type="checkbox"/> Design Modification
check one: <input type="checkbox"/> Standard Specification	<input type="checkbox"/> Supplemental Specification
<b>Plan Sheet No.:</b>	<b>Detail:</b>
	<input type="checkbox"/> Proposed VE
	<input type="checkbox"/> Special Provision

**REQUEST:**

**PROPOSED SOLUTION (If applicable):**

**By:** \_\_\_\_\_ **Signature:** \_\_\_\_\_ **Date:** \_\_\_\_\_

**RESPONSE:**

**By:** \_\_\_\_\_ **Signature:** \_\_\_\_\_ **Date:** \_\_\_\_\_

After reviewing the response, does the contractor anticipate:  
 That a change order will be required?  Yes  No  
 That there will be an increase in the cost of the project?  Yes  No

## Field Change Directive

**Project:** Project Name  
Address  
City, State Zip

**To:** Company  
Address  
City, State Zip

**Field Change Directive:**  
**Date:**

**Number:** Project Number  
**Contract Date:**

**YOU ARE HEREBY DIRECTED TO MAKE THE FOLLOWING CHANGES TO THE ABOVE NAMED CONTRACT:**

Item #	Description	Amount
1	Description	\$0.00
<b>Total</b>		<b>\$0.00</b>

### Contract Status Per This Change Order

The Time To Complete The Contract Is:

Unchanged  \_\_\_\_\_

Increased By \_\_\_\_\_ Days

Decreased By \_\_\_\_\_ Days

The Date Of Completion Is Now: \_\_\_\_\_

City of Northglenn \_\_\_\_\_

Owner

Company \_\_\_\_\_

Contractor

\_\_\_\_\_  
Name

\_\_\_\_\_  
Name

\_\_\_\_\_  
Title

\_\_\_\_\_  
Title

\_\_\_\_\_  
Signature

\_\_\_\_\_  
Signature

\_\_\_\_\_  
Date

\_\_\_\_\_  
Date

**Project:** Project Name

**Change Order #:** 1  
**Date:**

**To:** Company  
Address  
City, State Zip

**Contract Number:** Project Number  
**Contract Date:**

**YOU ARE HEREBY DIRECTED TO MAKE THE FOLLOWING CHANGES TO THE ABOVE NAMED CONTRACT:**

Item #	Description	Amount
1	Description	
<b>Total</b>		<b>\$0.00</b>

**Contract Status Per This Change Order**

Original Contract Sum	_____
Net Change By Previous Change Orders	\$0.00
Contract Sum Prior To This Change Order	\$0.00
Net Change Made By This Change Order	\$0.00
New Contract Sum	\$0.00

The Time To Complete The Contract Is:

Unchanged     x    

Increased By            Days

Decreased By            Days

The Date Of Completion Is Now: \_\_\_\_\_

City of Northglenn  
Owner  
Heather Geyer  
Name  
City Manager  
Title

Company  
Contractor  
Name  
Title

City of Northglenn  
Engineer  
Kent Kisselman, P.E.  
Name  
Director of Public Works  
Title

Signature

Signature

Signature

Date

Date

Date



**SECTION 013300 - SUBMITTAL PROCEDURES**

## PART 1 - GENERAL

## 1.1 RELATED DOCUMENTS

- A. Drawings and general provisions of the Contract apply to this Section.

## 1.2 SUMMARY

- A. This Section includes administrative and procedural requirements for submitting Shop Drawings, Product Data, Samples, and other submittals.

## 1.3 DEFINITIONS

- A. Action Submittals: Written and graphic information that requires Engineer's responsive action.
- B. Informational Submittals: Written information that does not require Engineer's responsive action. Submittals may be rejected for not complying with requirements.

## 1.4 SUBMITTAL PROCEDURES

- A. Coordination: Coordinate preparation and processing of submittals with performance of construction activities.
  - 1. Coordinate each submittal with fabrication, purchasing, testing, delivery, other submittals, and related activities that require sequential activity.
- B. Processing Time: Allow enough time for submittal review, including time for resubmittals, as follows. Time for review shall commence on Engineer receipt of submittal. No extension of the Contract Time will be authorized because of failure to transmit submittals enough in advance of the Work to permit processing, including resubmittals.
  - 1. Initial Review: Allow 10 days for initial review of each submittal. Allow additional time if coordination with subsequent submittals is required. Engineer will advise Contractor when a submittal being processed must be delayed for coordination.
  - 2. Intermediate Review: If intermediate submittal is necessary, process it in same manner as initial submittal.
  - 3. Resubmittal Review: Allow 10 days for review of each resubmittal.
- C. Deviations: Highlight or otherwise specifically identify deviations from the Contract Documents on submittals.
- D. Additional Copies: Unless additional copies are required for final submittal, and unless Engineer observes noncompliance with provisions in the Contract Documents, initial submittal may serve as final submittal.
- E. Submit a minimum of four paper copies of each submittal unless otherwise indicated. Two copies will be returned to the contractor.

1. Submit one copy of submittal to concurrent reviewer in addition to specified number of copies to Engineer.
  2. Submit five copies of operation and maintenance manuals.
- F. Transmittal: Package each submittal individually and appropriately for transmittal and handling. Transmit each submittal using a transmittal form. Engineer will return submittals, without review, received from sources other than Contractor.
1. Transmittal Form: Complete the sample form at end of Section and include with submittals. City will provide electronic version upon request. Include the following information:
    - a. Project name.
    - b. Date.
    - c. Name of Contractor.
    - d. Name of subcontractor.
    - e. Name of supplier.
    - f. Name of manufacturer.
    - g. Submittal number.
    - h. Number and title of appropriate Specification Section.
    - i. Drawing number and detail references.
    - j. Location(s) where product is to be installed.
    - k. Other necessary identification.
  2. On an attached separate sheet, prepared on Contractor's letterhead, record relevant information, requests for data, revisions other than those requested by Engineer on previous submittals, and deviations from requirements in the Contract Documents, including minor variations and limitations. Include same label information as related submittal.
- G. Resubmittals: Make resubmittals in same form and number of copies as initial submittal.
1. Note date and content of previous submittal.
  2. Note date and content of revision in label or title block and clearly indicate extent of revision.
  3. Resubmit submittals until they are marked "A - NO EXCEPTIONS TAKEN or B - FURNISH AS CORRECTED".
- H. Distribution: Furnish copies of final submittals to manufacturers, subcontractors, suppliers, fabricators, installers, authorities having jurisdiction, and others as necessary for performance of construction activities. Show distribution on transmittal forms.
1. Use for Construction: Use only final submittals with mark indicating "A - NO EXCEPTIONS TAKEN or B - FURNISH AS CORRECTED" taken by Owner's Representative.
- I. Required Submittals: (This is not an all inclusive list. Engineer reserves the right to request additional submittals as required.)
1. Project Schedule
  2. Subcontractor list if applicable
  3. All other requested submittals in separate sections.

## PART 2 - PRODUCTS

## 2.1 ACTION SUBMITTALS

- A. General: Prepare and submit Action Submittals required by individual Specification Sections.
  - 1. Submit electronic submittals directly to extranet specifically established for Project.
- B. Product Data: Collect information into a single submittal for each element of construction and type of product or equipment.
  - 1. If information must be specially prepared for submittal because standard printed data are not suitable for use, submit as Shop Drawings, not as Product Data.
  - 2. Mark each copy of each submittal to show which products and options are applicable.
  - 3. Include the following information, as applicable:
    - a. Manufacturer's written recommendations.
    - b. Manufacturer's product specifications.
    - c. Manufacturer's installation instructions.
    - d. Manufacturer's catalog cuts.
    - e. Compliance with specified referenced standards.
    - f. Testing by recognized testing agency.
    - g. Application of testing agency labels and seals.
    - h. Notation of coordination requirements.
- C. Shop Drawings: Prepare Project-specific information, drawn accurately to scale. Do not base Shop Drawings on reproductions of the Contract Documents or standard printed data, unless submittal of Engineer's CAD Drawings are otherwise permitted.
- D. Samples: Submit Samples for review of kind, color, pattern, and texture for a check of these characteristics with other elements and for a comparison of these characteristics between submittal and actual component as delivered and installed.
- E. Subcontract List: Prepare a written summary identifying individuals or firms proposed for each portion of the Work, including those who are to furnish products or equipment fabricated to a special design. Include the following information in tabular form:
  - 1. Name, address, and telephone number of entity performing subcontract or supplying products.

## 2.2 INFORMATIONAL SUBMITTALS

- A. General: Prepare and submit Informational Submittals required by other Specification Sections.
- B. Qualification Data: Prepare written information that demonstrates capabilities and experience of firm or person. Include lists of completed projects with project names and addresses, names and addresses of Owner's Representatives and owners, and other information specified.
- C. Welding Certificates: Prepare and provide documentation that welding procedures and personnel comply with AWS requirements. Include names of firms and personnel certified.
- D. Product Certificates: Prepare written statements on manufacturer's letterhead certifying that product complies with requirements in the Contract Documents.

- E. **Material Certificates:** Prepare written statements on manufacturer's letterhead certifying that material complies with requirements in the Contract Documents.
- F. **Design Data:** Prepare written and graphic information, including, but not limited to, performance and design criteria, list of applicable codes and regulations, and calculations. Include list of assumptions and other performance and design criteria and a summary of loads. Include load diagrams if applicable. Provide name and version of software, if any, used for calculations. Include page numbers.
- G. **Manufacturer's Instructions:** Prepare written or published information that documents manufacturer's recommendations, guidelines, and procedures for installing or operating a product or equipment. Include name of product and name, address, and telephone number of manufacturer. Include the following, as applicable:
- H. **Material Safety Data Sheets (MSDSs):** Submit information directly to Owner; do not submit to Owner's Representative.
  - 1. Owner's Representative will not review submittals that include MSDSs and will return the entire submittal for resubmittal.

### 2.3 DELEGATED DESIGN

- A. **Performance and Design Criteria:** Where professional design services or certifications by a design professional are specifically required of Contractor by the Contract Documents, provide products and systems complying with specific performance and design criteria indicated.
  - 1. If criteria indicated are not sufficient to perform services or certification required, submit a written request for additional information to Engineer.
- B. **Delegated-Design Submittal:** In addition to Shop Drawings, Product Data, and other required submittals, submit three copies of a statement, signed and sealed by the responsible design professional, for each product and system specifically assigned to Contractor to be designed or certified by a design professional.
  - 1. Indicate that products and systems comply with performance and design criteria in the Contract Documents. Include list of codes, loads, and other factors used in performing these services.

## PART 3 - EXECUTION

### 3.1 CONTRACTOR'S REVIEW

- A. **Review each submittal and check for coordination with other Work of the Contract and for compliance with the Contract Documents.** Note corrections and field dimensions. Mark with approval stamp before submitting to Engineer.
- B. **Approval Stamp:** Stamp each submittal with a uniform, approval stamp. Include Project name and location, submittal number, Specification Section title and number, name of reviewer, date of Contractor's approval, and statement certifying that submittal has been reviewed, checked, and approved for compliance with the Contract Documents.

### 3.2 OWNER'S REPRESENTATIVE'S AND CONSTRUCTION MANAGER'S ACTION

- A. General: Engineer will not review submittals that do not bear Contractor's approval stamp and will return them without action.
- B. Action Submittals: Engineer will review each submittal, make marks to indicate corrections or modifications required, and return it. Engineer will stamp each submittal with an action stamp and will mark stamp appropriately to indicate action taken, as follows:
  - 1. A - NO EXCEPTIONS TAKEN
  - 2. B - FURNISH AS CORRECTED
  - 3. C - REJECTED – SEE REMARKS
  - 4. D - REVISE AND RESUBMIT
- C. Informational Submittals: Engineer will review each submittal and will not return it, or will return it if it does not comply with requirements. Engineer will forward each submittal to appropriate party.
- D. Partial submittals are not acceptable, will be considered nonresponsive, and will be returned without review.
- E. Submittals not required by the Contract Documents may not be reviewed and may be discarded.



**SECTION 013500 - SPECIAL CONDITIONS**

## PART 1 - GENERAL

## 1.1 PROJECT DESCRIPTION

- A. The Contractor shall furnish all material, labor, equipment and services necessary for, and incidental to, the WWTF Aeration Diffuser Replacement as specified.

## 1.2 LOCATION OF WORK

- A. The work is located the Northglenn Waste Water Treatment Facility, 5445 County Rd 2, Northglenn, Colorado 80603. Prospective bidders should make themselves familiar with the location of the work and all potential access points so as to facilitate progress of the work in a well-organized fashion.

## 1.3 TIME OF WORK

- A. The Contractor shall complete all work required by these specifications within (150) calendar days. The starting time for the Contract shall be ten (10) calendar days following the date of the Notice to Proceed. Working hours shall be **7:00 A.M. to 5:00 P.M.** Monday through Friday. A working day shall be defined as any day, exclusive of Saturdays, Sundays and holidays, on which weather and other conditions not under the control of the Contractor will permit construction to proceed for a minimum of one half (1/2) of the day with a normal working force. See Trade Contractor Agreement.

The Contractor shall be responsible for submitting a schedule for all work to be performed. Schedule to be submitted monthly with each pay application request. Pay application requests are considered incomplete and will not be processed if submitted without a schedule update.

## 1.4 PROTECTION OF EXISTING UTILITIES

- A. The Contractor shall be responsible for the protection of existing utilities and any other utilities and plant infrastructure such as water mains, sanitary and storm sewer systems, gas mains, electrical conduits, telephone lines, irrigation systems and any other utilities within the area; and if any damage or destruction occurs to these utilities, the Contractor shall be responsible for their repair and/or replacement at the Contractors expense.

## 1.5 QUALITY ASSURANCE

- A. Referenced Standards:
1. City of Northglenn, Public Right-of-Way Standards and Specifications (Current Edition). The Public Right-of-Way Standards and Specifications are available on the city of Northglenn website.
  2. Latest City of Northglenn adopted Building Code.
  - ~~3. Colorado Reg. 8 and Federal regulations for the removal of asbestos.~~

- B. In the event of a conflict occurring between or within the aforementioned Standards and Specifications and the project specifications, the more stringent standard will apply. The Contractor shall coordinate inspection of the work with Engineer. Any discrepancies found between the Drawings and Specifications and site conditions or any errors or omissions in the Drawings or Specifications shall be immediately reported in writing to the Engineer, who shall promptly correct such errors, or omissions in writing. Any work done by the Contractor after his discovery of such discrepancies, errors or omissions WITHOUT written instructions by the Engineer shall be done at the Contractor's risk.
- C. City of Northglenn's Standard Operating Procedures.

#### 1.6 LIQUIDATED DAMAGES

- A. Liquidated damages shall be set at \$200.00 per day. See Trade Contractor Agreement.

#### 1.7 SPECIAL CONSIDERATIONS

- A. Contractor shall be responsible for negotiations of any waivers or alternate arrangements required to enable transportation of materials to the site.
- B. Contractor shall be responsible for adhering to the city of Northglenn's Standard Operating Procedures.
- C. Contractor shall coordinate with the Chief Plant Operator to empty and prepare each basin for diffuser replacement a minimum of 3 weeks prior to commencing work. No more than one aeration basin may be offline at a time.

#### 1.8 SPECIAL CONTRACT PROVISION

- A. The items listed in the Bid Summary are estimated for comparison purposes only.

#### 1.9 CONTRACT DOCUMENTS FOR CONTRACTORS USE

- A. Refer to Trade Contractor Agreement.
- ~~B. Contractor shall pick up two "no charge" documents within 10 days from date of Notice to Proceed.~~

#### 1.10 ORDER OF CONSTRUCTION AND CONSTRUCTION SCHEDULE

- A. Construction operations will be scheduled to allow the Owner uninterrupted operation of existing adjacent facilities. Coordinate connections with existing work to ensure timely completion of interfaced items.
- B. At no time shall Contractor or his employees modify operation of the existing facilities or start construction modifications without approval of the Owner except in emergency to prevent or minimize damage.
- C. Within 10 days after award of Contract, submit for approval a critical path type schedule. Account for schedule of Subcontracts. Include proper sequence of construction, various crafts, purchasing time, shop drawing approval, material delivery, equipment fabrication, startup, demonstration, and similar time consuming factors. Show on schedule as a minimum, earliest starting, earliest completion, latest starting, latest finish, and free and total float for each task or item.



The owner considers the pay application to be incomplete and will not be processed without a schedule update. Evaluate schedule no less than monthly, if applicable. Update, correct, and rerun schedule and submit to Engineer in triplicate with pay application and show rescheduling necessary to reflect true job conditions. When shortening of various time intervals is necessary to correct for behind schedule conditions, indicate steps to implement to accomplish work in shortest schedule. Information shall be submitted to Engineer in writing with revised schedule.

- D. If Contractor does not take necessary action to accomplish work according to schedule, he may be ordered by Owner in writing to take necessary and timely action to improve work progress. Order may require increased work forces, extra equipment, extra shifts or other action as necessary. Should Contractor refuse or neglect to take such action authorized, under provisions of this contract, Owner may take necessary actions including, but not necessarily limited to, withholding of payment and termination of contract.

#### 1.11 PERMITS

- A. Contractor is responsible for securing all required permits for the completion of the work with all agencies with jurisdictional authority. Below is a list of required permits. This is not an all encompassing list of permits that may be required.

1. ~~Right of Way Permit~~ Required, but City at its sole discretion, may waive fees
2. Northglenn Contractor's license. See [https://www.northglenn.org/government/departments/building/contractor\\_license.php](https://www.northglenn.org/government/departments/building/contractor_license.php)

#### 1.12 SAFETY AND HEALTH REGULATIONS FOR CONSTRUCTION

- A. These construction documents are to be governed, at all times, by applicable provisions of the Federal Law(s), including but not limited to the latest amendment of the following:
1. Williams-Steiger Occupational Safety and Health Act of 1970, Public Law 94-596.
  2. Part 1910-Occupational Safety and Health Standards, Chapter XVII of Title 29, Code of Federal Regulations.
  3. Part 1926-Safety and Health Regulations for Construction, Chapter XVII of Title 29, Code of Federal Regulations.
  4. Part II Department of Labor Occupational Safety and Health Administration 29CFR Part 1926 Occupational Safety and Health Standards - Excavations; Final Rule.

#### 1.13 PRECONSTRUCTION CONFERENCE

- A. A pre-construction conference shall be held at the Owner's office after award of Contract. Engineer will notify the Contractor as to the date and time of the conference 2 weeks in advance of the proposed date. Contractor's Project Manager and Project Superintendent and Contractor's Subcontractor Representatives shall attend. The Contractor should be prepared to discuss a detailed plan for construction of the project at the meeting.

#### 1.14 PROGRESS MEETING

- A. The Engineer will conduct construction meetings involving:

1. Contractor’s project manager
  2. Contractor’s project superintendent
  3. Engineer’s designated representative(s).
  4. Contractor’s subcontractors as appropriate to the work in progress.
- B. The Engineer’s designated representative(s) will take meeting minutes and submit copies of the meeting minutes to participants and designated recipients identified at the Preconstruction Conference. Corrections, additions or deletions to the minutes shall be noted and addressed at the following meeting.
- C. The Engineer’s designated representative(s) will have available at each meeting full chronological file of all previous meeting minutes.
- D. The Contractor shall have available at each meeting up-to-date record drawings.
- E. The Contractor shall provide a two-week schedule projection at each weekly meeting.

1.15 CHANGE MODIFICATION PROCEDURES

- A. Request for Information (RFI’s)
1. Contractor shall request clarification of contract documents by issuing a Request for Information to the RPR. Contractor shall afford at least 48 hours for Engineer’s response. Engineer will provide electronic copy upon request.
- B. Field Orders:
1. A written order effecting a change in the work not involving an adjustment in the contract price or an extension of the contract time, issued by the Engineer or the Owner to the Trade Contractor during Construction.
- C. Change Order:
1. A written order to the Trade Contractor authorizing an addition, deletion, or revision in the work within the general scope of the contract documents, or authorizing an adjustment in the contract price and/or contract time. Owner will provide electronic copy upon request.

1.16 MEASUREMENT AND PAYMENT

- A. General:
1. The total bid price shall cover all work required by the Contract Documents. All costs in connection with the proper and successful completion of the work, including furnishing all materials, equipment, supplies, and appurtenances; providing all construction, installation equipment, and tools; and performing all necessary labor and supervision to fully complete the work and any mark-up, shall be included in the unit and/or lump sum prices bid. No item of work shown on the drawings or in the specifications will be considered for extra compensation due to a claim that it does not fall within the scope of one of the bid items.

B. Estimated Quantities:

1. The estimated quantities identified in the Bid Summary are approximate and are to be used only (a) as a basis for estimating the probable cost of the work. The actual amounts of work done and materials furnished under unit price items may differ from the estimated quantities. The basis of payment for work and materials will be the actual amount of work completed and materials furnished per the unit or lump sum prices shown on the bid summary.
2. No direct payment shall be made for site clearing and cleaning, excavation, or compaction accordance with industry standards and governing regulations.

C. Measurement and Payment Items:

1. Bid Item – Mobilization & Demobilization: The measurement and payment for Mobilization & Demobilization shall be on a lump sum basis. Contractor’s cost shall include all cost associated with mobilization and demobilization, regardless of nature.

The unit price shall include at a minimum:

- a. Mobilization/demobilization of material labor and equipment.
- b. Bonds, insurance, licenses, and permits.
- c. Temporary construction and erosion control. The contractor shall perform street sweeping as needed as determined by the Engineer.
- d. Direct site overhead including staging area, field office facilities for the contractor, moving and removing construction equipment to/from the project site and removal of any items placed on site by the Contractor.
- e. All other costs incurred or labor and operations which must be performed prior to and after completion of the other items under this Contract in accordance with the Plans and Specifications.
- f. The lump sum price for Mobilization and Demobilization shall not exceed 5% of the total contract value and shall be paid as the work progresses, according to the following schedule:

Contract Work Complete	Percent Available for Payment
5%	25%
50%	60%
100%	100%

PART 2 - PRODUCTS

SEE EXHIBIT A FOR ACCEPTABLE PRODUCTS AND OWNERS SUPPLIED PRODUCTS.

PART 3 - EXECUTION

3.1 CONSTRUCTION REQUIREMENTS

- A. Contractor shall take reasonable precaution to prevent damage to existing facilities. All facilities damaged or removed during construction shall be restored or replaced to like new condition.
- B. ~~Contractor to make all payments for the removal and disposal of asbestos containing materials as shown in the environmental assessment in accordance with all state and federal regulations.~~

- C. Start-up procedures shall have a Xylem representative oversee and validate the results of the start-up. All costs borne with procuring a representative shall be the contractor's responsibility. If the startup is not successful for any reason that is not caused by the owner, the full cost of the representative's return visit will be paid by the contractor at no additional cost to the owner.

**END OF SECTION 013500**



City of Northglenn  
Public Works Department  
11701 Community Center Drive  
Northglenn, Colorado 80233

---

## Exhibit A - Scope of Work

## **Section 1 – Background Information and Photos**

The aeration system was initially installed in 2007. Considering the prolonged absence of headworks over the years, the aeration system has undergone a deterioration process, necessitating the complete replacement of the PVC aeration system across all three aeration basins. Attempts to address issues through maintenance patches have proven insufficient, leading to the need for the replacement of entire laterals. The current state renders patching unfeasible, requiring an overhaul.

The system, initially installed in 2007 under Sanitaire Project No: 04-575OS, Specification Section 11337, the guidelines provided in the installation instructions and start-up guides, in accordance with the manufacturer's recommendations should be followed by the contractor.

Please note that all blanks have been put into service and the replacement will require all diffusers and no blanks. The vertical purge assembly will only be replaced up to the  $\frac{3}{4}$  inch sch 80 PVC, as indicated in drawing E-10. Additionally, an evaluation of all mounting hardware is necessary, and replacement should be carried out on an as-needed basis.

The proposed pricing should include material procurement, installation, and start-up procedures shall be performed in accordance with the manufacturer's recommendations per each basin.



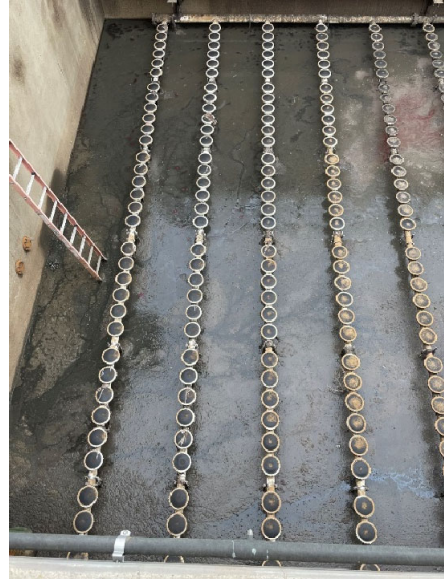

# Section 2 - Drawings

USE SUPPORT 2346-2SP ON THESE DISTRIBUTORS SEE DETAIL SUP-1 ON SHEET 8  
 USE SUPPORT 2346-3SP ON THESE DISTRIBUTORS SEE DETAIL SUP-1 ON SHEET 8  
 USE SUPPORT 2354-4SP ON THESE DISTRIBUTORS SEE DETAIL SUP-2 ON SHEET 8

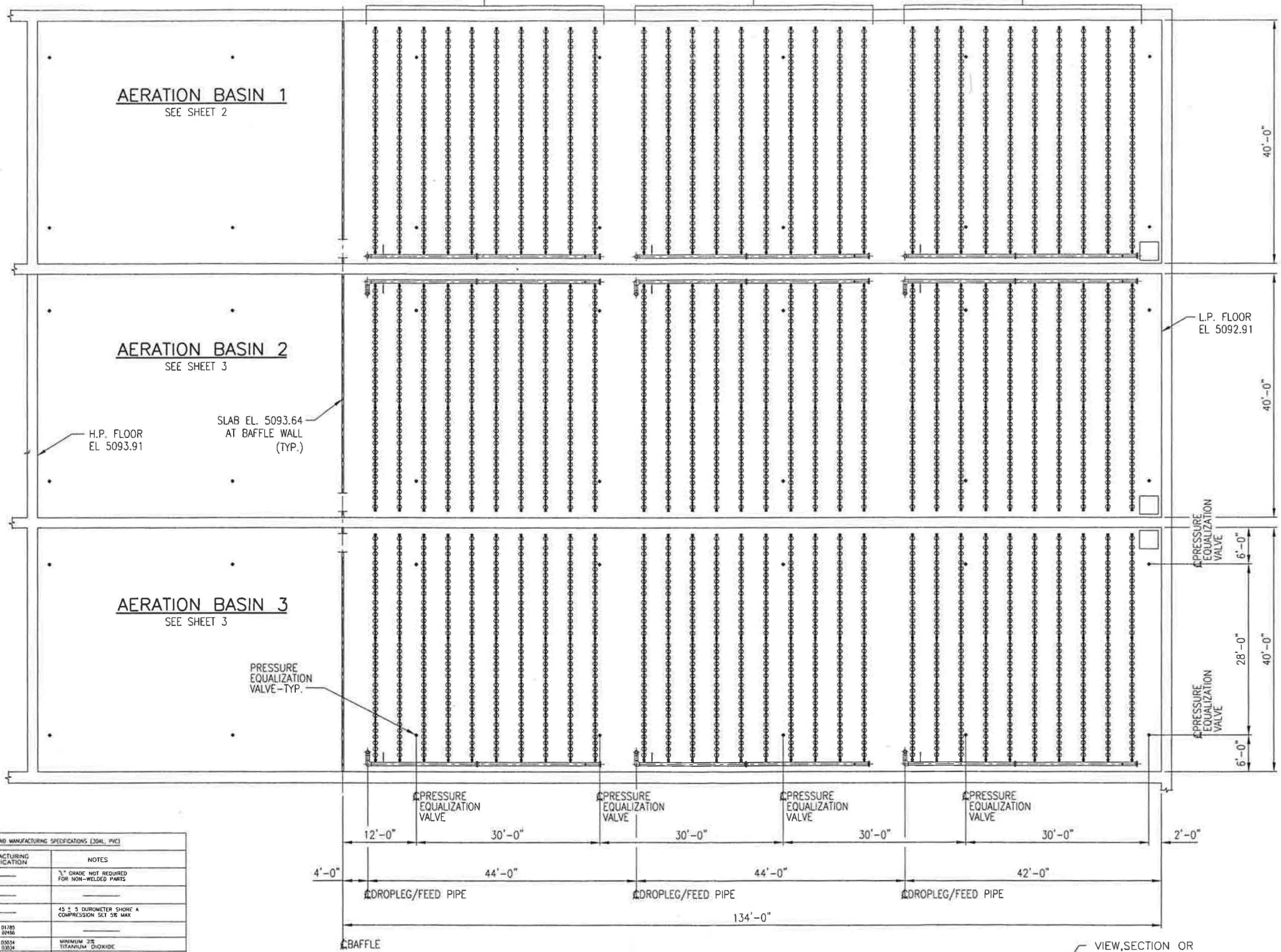

NOTES:  
 1. NO PRESSURE EQUALIZATION VALVE DOWN CENTER OF BASINS AS PER DRAWINGS S-3000 & S-3001.

APPROVED FOR CONSTRUCTION  
 APR 22 2005  
 SANITAIRE

ITEM	MATERIAL SPECIFICATION	MANUFACTURING SPECIFICATION	NOTES
SUPPORTS	316 STAINLESS STEEL SHEETS & PIPES PER ASTM A240 THICKED 800 PER ASTM A240		1/2" GRADE NOT REQUIRED FOR NON-WELDED PARTS
BOLTS, NUTS, WASHERS	16-8 STAINLESS STL		
FIXED JOINT O-RING	NATURAL RUBBER/SBR		45 ± 5 DUROMETER SHORE A COMPRESSION SET 5% MAX
LOWER DROPLEG & MANIFOLD	PVC, ASTM D1784 COMPOUND 12454-B	PVC FITTINGS: ASTM D1785	
AIR DISTRIBUTORS	PVC, ASTM D3915 COMPOUND 124524	PVC FITTINGS: ASTM D3914	MINIMUM 2% TITANIUM DIOXIDE
DIFFUSER HOLDER SUBPLATE, RETAINING RING	PVC, ASTM D3915 COMPOUND 124524		MINIMUM 2% TITANIUM DIOXIDE
DIFFUSER ELEMENT	EPDM		
PVC SOLVENT WELDING	ASTM D2564	ASTM D2855	

\*STAINLESS STEEL DROPLEG FABRICATION  
 FACTORY WELD ONLY WITH MIG, TIG, OR PLASMA-ARC WELDING W/ERT GAS PROTECTORS. FULL PENETRATION BUTT WELDS. ER 316L FILLER WIRE. AFTER FABRICATION FINISH CLEAN ALL WELDED STAINLESS STEEL ASSEMBLIES BY FULL IMMERSION CLEANING TECHNIQUE'S IN ACCORDANCE TO 6.2.11 OF ASTM A380-88. THE AOD FOR USE DEFINED BY TABLE A2.1 OF ANNEX A2 OF ASTM A380. FINAL RINSE AND DRY IN ACCORDANCE TO SECTION 8.3 OF ASTM A380. ALL WELDED SURFACES TO CONFORM TO AOD NO. 20 FINISH.

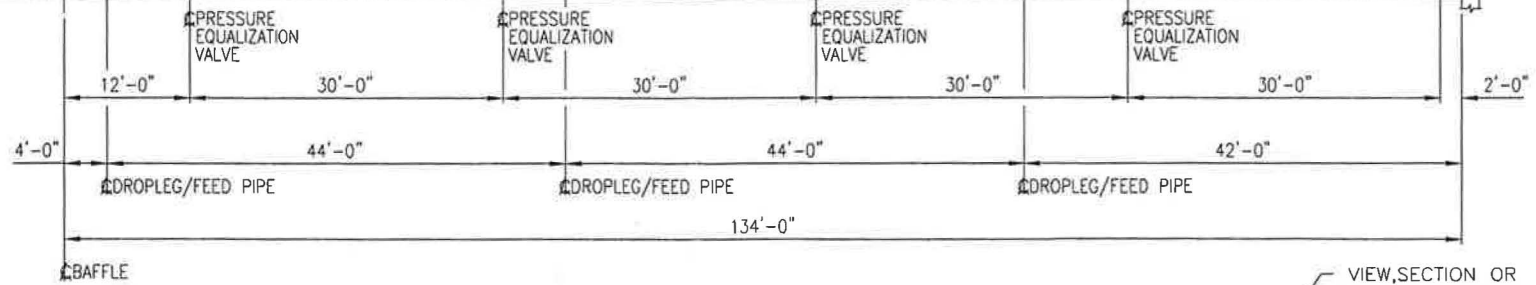

AERATION BASINS 1, 2 & 3  
 (1) REQ'D AS SHOWN  
 KEY PLAN 1

VIEW, SECTION OR DETAIL NUMBER  
 2  
 3  
 SHEET NUMBER ON WHICH VIEW, SECTION OR DETAIL IS FOUND

4			
3			
2			
1			
NO.	DATE	REVISION	BY
NORTHGLENN, CO WWTP			
THIS DRAWING IS THE PROPERTY OF SANITAIRE AND IS SUBMITTED IN CONFIDENCE. IT IS NOT TO BE DISCLOSED, USED OR DUPLICATED WITHOUT PERMISSION OF SANITAIRE.			
AERATION BASINS 1, 2 & 3			
KEY PLAN			
Sanitaire ITT Industries			
SANITAIRE BROWN DEER, WISCONSIN 53223 ABJ			
DRWN BY	NC	DATE 4-14-05	EQUIP. NEW
CHD BY	BB	DATE 4-18-05	STD.
APP'D BY	BB	DATE 4-21-05	SIZE D REV.
			04-5750S
			1 OF 10



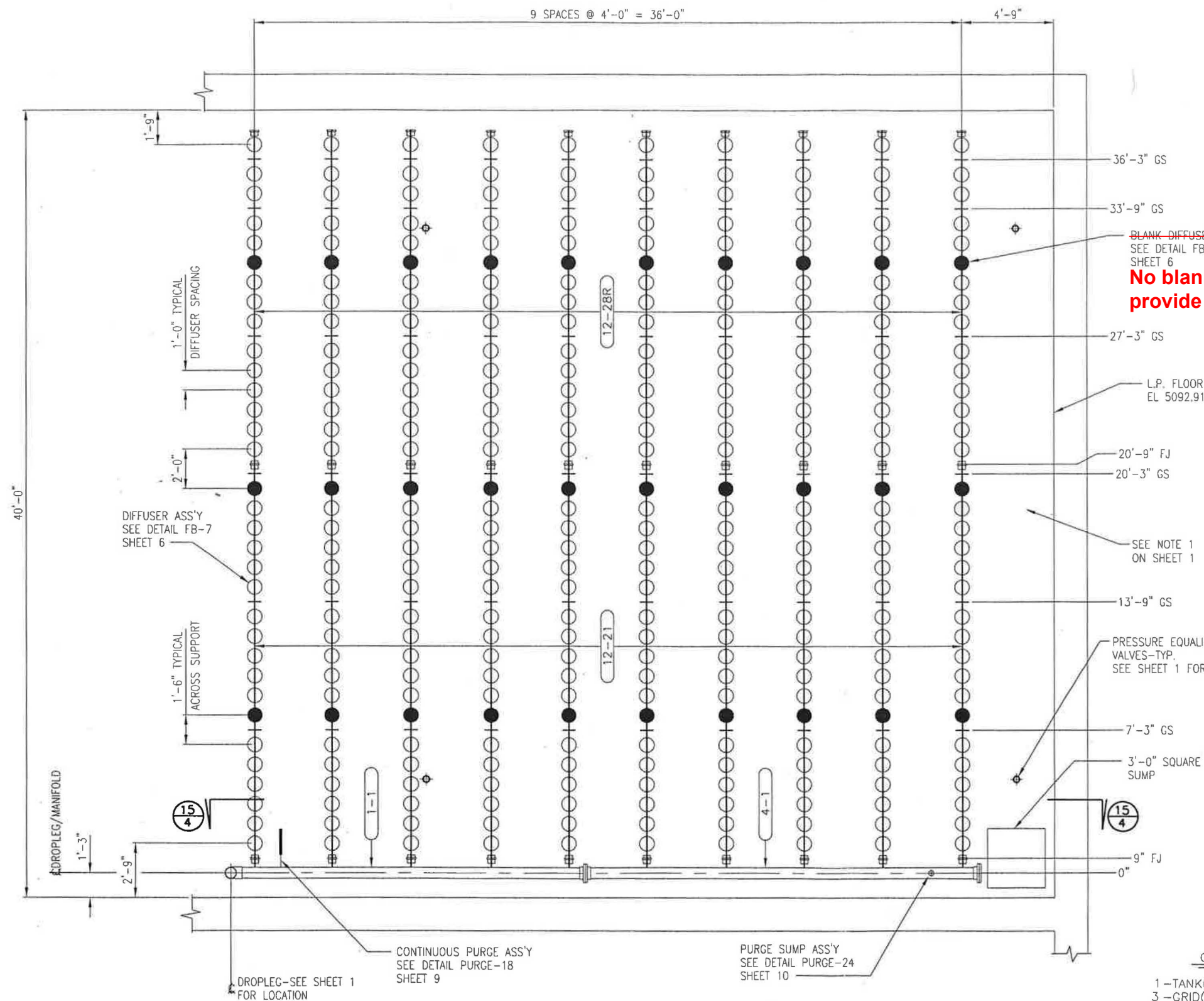

**NOTE: SUPPORT SPACING**

Every attempt has been made to insure locational dimensions of the supports are correct. However, after one line of air distributor anchors for any grid type have been installed, the locations must be checked for proper clearances by installing the supplied air headers. Spacing between lines must be checked for fit with the cross manifold and drain line. Any discrepancies or interferences must be brought to the attention of SANITAIRE prior to further installation.

The actual support anchor locations must be indexed from the centerline of the manifold. The actual accumulative dimensional error from the manifold to the anchor bolt must not exceed  $\pm 3/4"$ .

**No blanks. Only provide diffusers.**



- LEGEND**
- FJ - FIXED JOINT  
SEE DETAIL FB-10A  
SHEET- 7
  - GS - GUIDE SUPPORT-SEE SHEET 1  
FOR SUPPORT TYPE & LOCATION
  - FOR TYPICAL AIR DISTRIBUTOR SECTION  
SEE DETAIL FB-22D  
SHEET- 6

**GRID TYPE '1'**

- 1 -TANK(S)
- 3 -GRID(S) PER TANK
- 10 -AIR DISTRIBUTORS PER GRID
- 33 -DIFFUSER HOLDERS PER AIR DISTRIBUTOR
- 30 -DIFFUSER ELEMENTS PER AIR DISTRIBUTOR
- 300 -DIFFUSER ELEMENTS INSTALLED PER GRID
- 900 -TOTAL DIFFUSER ELEMENTS INSTALLED FOR THIS GRID TYPE
- 30 -TOTAL BLANKS PER GRID

**AERATION BASIN 1**

(3) REQ'D AS SHOWN

**PLAN VIEW 5**

4			
3			
2			
1			
NO.	DATE	REVISION	BY

NORTHGLENN, CO  
WWTP

THIS DRAWING IS THE PROPERTY OF SANITAIRE AND IS SUBMITTED IN CONFIDENCE. IT IS NOT TO BE DISCLOSED, USED OR DUPLICATED WITHOUT PERMISSION OF SANITAIRE.

AERATION BASIN 1

PLAN VIEW

Sanitaire  
ITT Industries  
BROWN DEER, WISCONSIN 53223

DRWN BY	MC	DATE	4-14-05	EQUIP.	MEW	NO.	04-5750S	SHT.	2
CHKD BY		DATE	4-18-05	SIZE	D	REV.		OF	10
APPVD BY		DATE		SIZE	D	REV.	E-2		

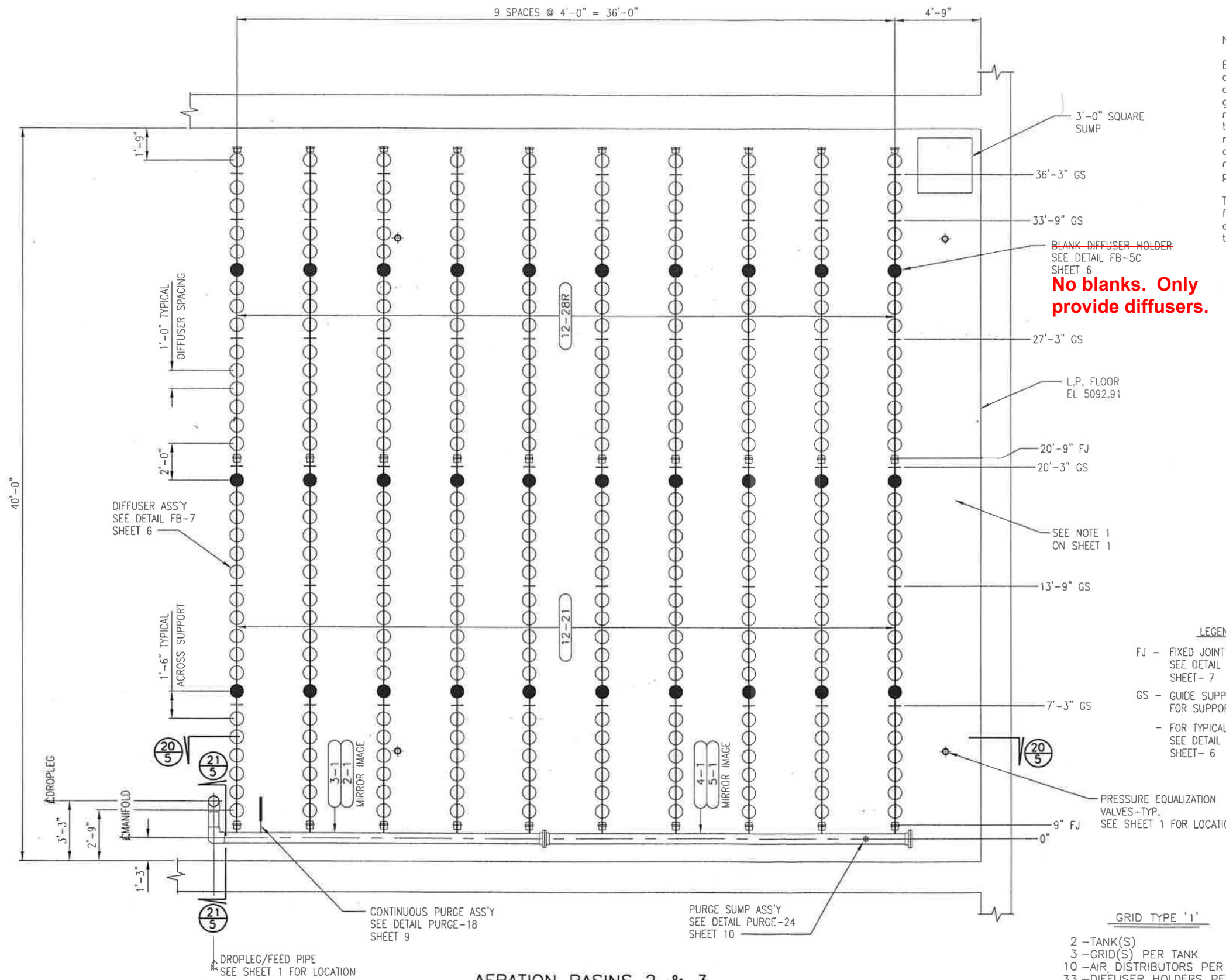

NOTE: SUPPORT SPACING

Every attempt has been made to insure locational dimensions of the supports are correct. However, after one line of air distributor anchors for any grid type have been installed, the locations must be checked for proper clearances by installing the supplied air headers. Spacing between lines must be checked for fit with the cross manifold and drain line. Any discrepancies or interferences must be brought to the attention of SANITAIRE prior to further installation.

The actual support anchor locations must be indexed from the centerline of the manifold. The actual accumulative dimensional error from the manifold to the anchor bolt must not exceed  $\pm 3/4"$ .

~~BLANK DIFFUSER HOLDER~~  
SEE DETAIL FB-5C  
SHEET 6  
**No blanks. Only provide diffusers.**



- LEGEND**
- FJ - FIXED JOINT  
SEE DETAIL FB-10A  
SHEET- 7
  - GS - GUIDE SUPPORT-SEE SHEET 1  
FOR SUPPORT TYPE & LOCATION
  - FOR TYPICAL AIR DISTRIBUTOR SECTION  
SEE DETAIL F-22D  
SHEET- 6

**GRID TYPE '1'**

- 2 -TANK(S)
- 3 -GRID(S) PER TANK
- 10 -AIR DISTRIBUTORS PER GRID
- 33 -DIFFUSER HOLDERS PER AIR DISTRIBUTOR
- 30 -DIFFUSER ELEMENTS PER AIR DISTRIBUTOR
- 300 -DIFFUSER ELEMENTS INSTALLED PER GRID
- 1800 -TOTAL DIFFUSER ELEMENTS INSTALLED FOR THIS GRID TYPE
- 30 -TOTAL BLANKS PER GRID

**AERATION BASINS 2 & 3**  
(3) REQ'D AS SHOWN-BASIN 3  
(3) REQ'D MIRROR IMAGE-BASIN 2  
**PLAN VIEW** 10

4			
3			
2			
1			
NO.	DATE	REVISION	BY
NORTHGLENN, CO WWTP			
AERATION BASINS 2 & 3			
PLAN VIEW			
Sanitaire ITT Industries			
DRWN BY MC	DATE 4-14-05	EQUIP. MEM	JOB 04-5750S
CHKD BY BB	DATE 4-18-05	SIZE D	REV E-3
APPROD BY	DATE	REV	OF 10

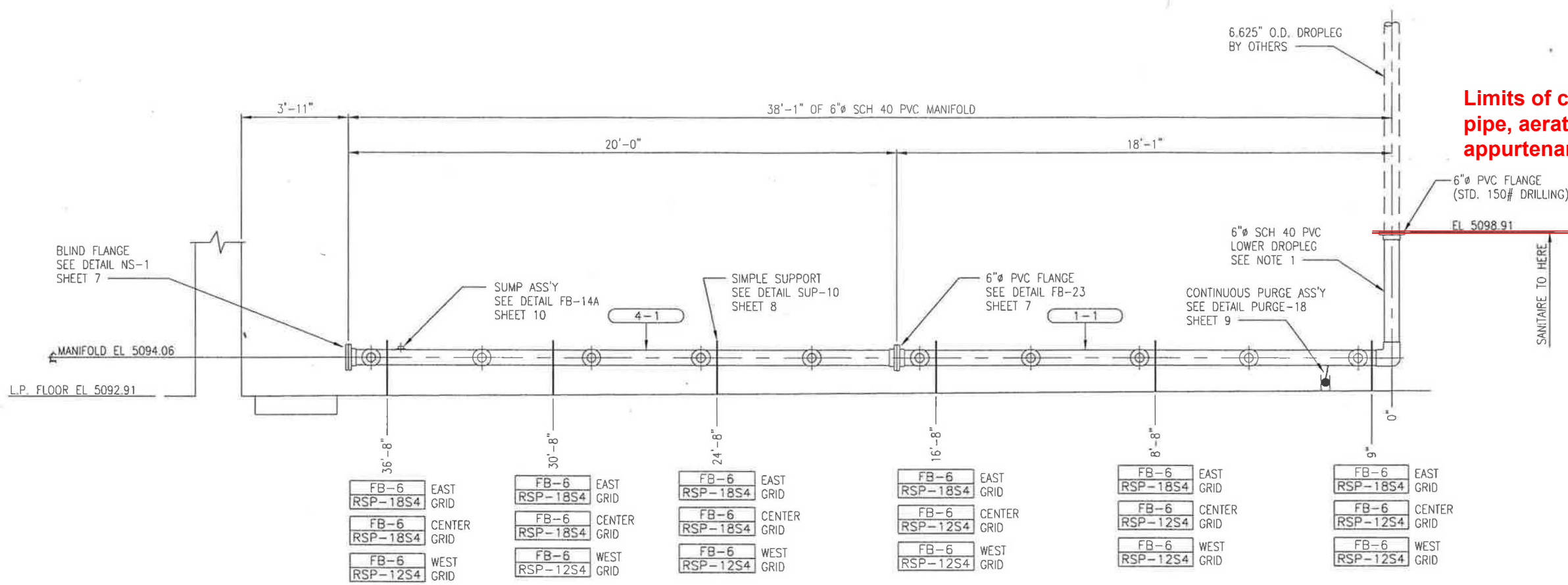

Limits of construction are all PVC pipe, aeration diffusers, and appurtenances below the red line.

DROPLEG/MANIFOLD-AERATION BASIN 1  
 (3) REQ'D AS SHOWN  
 SECTION 15

NOTES:

- PVC DROPLEG WILL BE SHIPPED TO JOBSITE 6" LONGER THAN REQUIRED, TO ACCOUNT FOR TANK VARIANCES. CONTRACTOR TO CUT TO SUIT AND SOLVENT WELD INTO MANIFOLD.
- |          |
|----------|
| FB-X     |
| RSP-XXXX |

 REFERS TO THE MANIFOLD SUPPORT SIZE AND CORRESPONDS TO THE TABLE SHOWN WITH THE SUPPORT DETAIL.  
 INDICATES THE SUPPORT STAND PART NUMBER.

4			
3			
2			
1			
NO	DATE	REVISION	BY
NORTHGLENN, CO WWTP			
AERATION BASIN 1 DROPLEG/MANIFOLD SECTION			
Sanitaire ITT Industries			
SANITAIRE BROWN DEER, WISCONSIN 53223 ABJ			
DRWN BY	MC	DATE 4-14-05	EQUIP. NEW
CHKD BY	BB	DATE 4-18-05	STD.
APPRD BY		DATE	SIZE D REV
			JOB 04-5750S
			4 OF 10
			ENC E-4

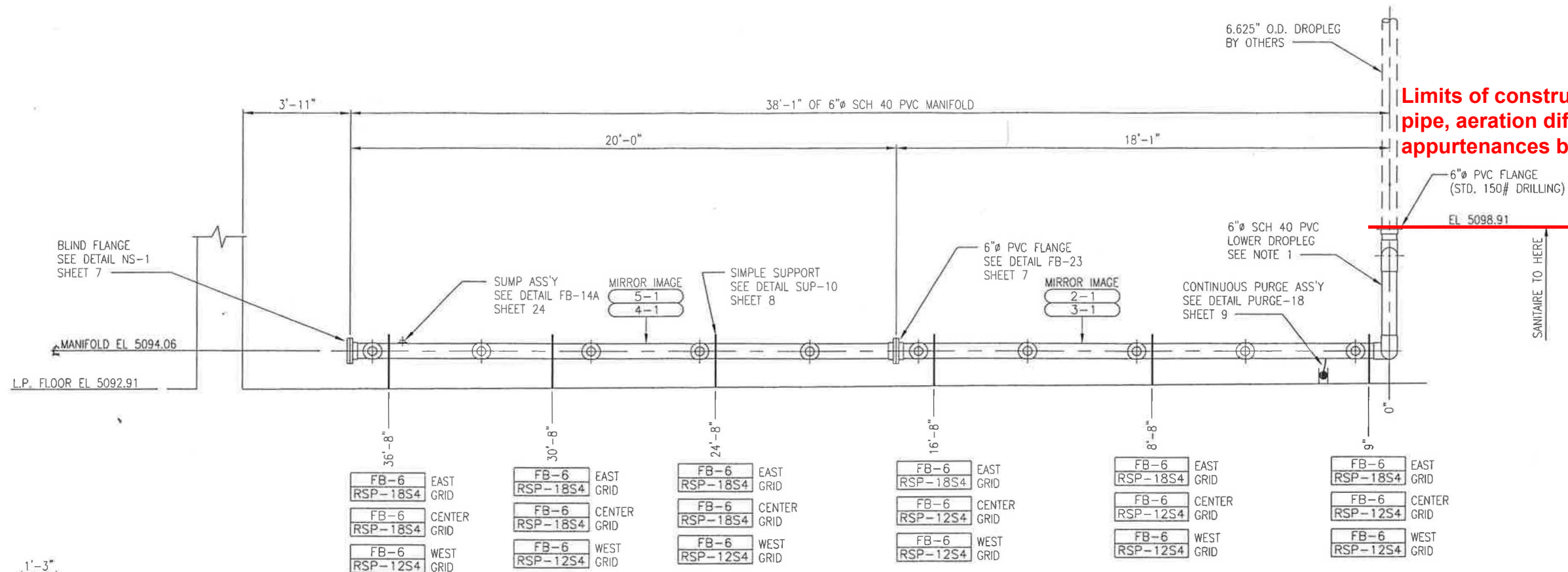

Limits of construction are all PVC pipe, aeration diffusers, and appurtenances below the red line.

**DROPLEG/MANIFOLD-AERATION BASINS 2 & 3**

(3) REQ'D AS SHOWN-BASIN 3  
(3) REQ'D MIRROR IMAGE-BASIN 2

**SECTION 20**

Limits of construction are all PVC pipe, aeration diffusers, and appurtenances below the red line.

Contractor to protect and preserve 16 inch MLR line at all times.

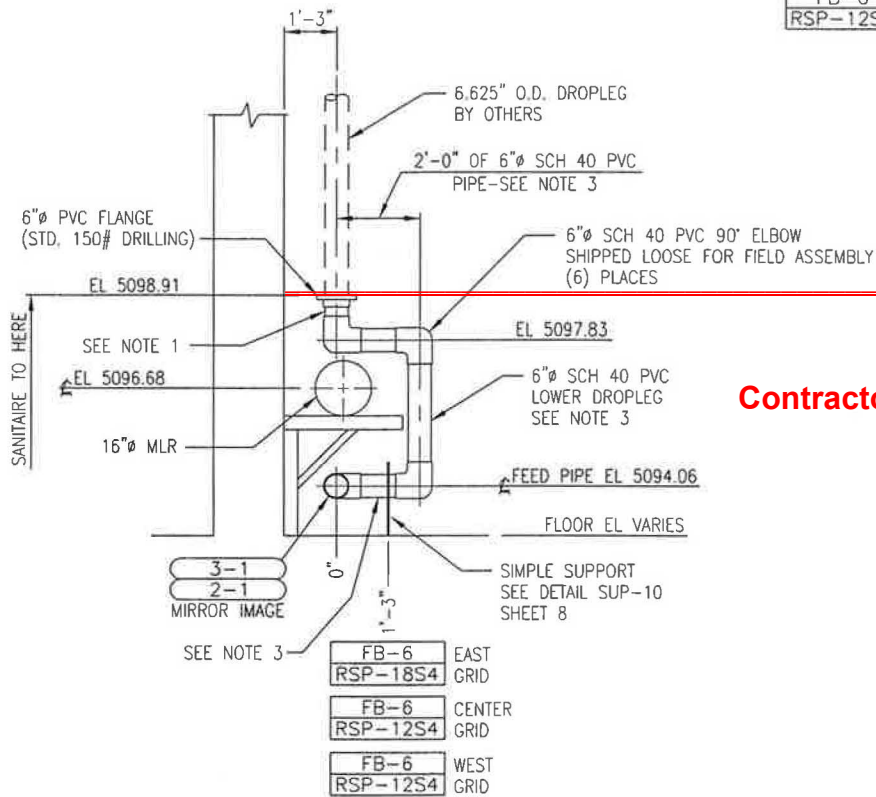

**DROPLEG/MANIFOLD/FEED PIPE-AERATION BASINS 2 & 3**

(3) REQ'D AS SHOWN-BASIN 3  
(3) REQ'D MIRROR IMAGE-BASIN 2

**SECTION 21**

**NOTES:**

- PVC DROPLEG WILL BE SHIPPED TO JOBSITE 6" LONGER THAN REQUIRED, TO ACCOUNT FOR TANK VARIANCES. CONTRACTOR TO CUT TO SUIT AND SOLVENT WELD INTO MANIFOLD.
- |          |   |
|----------|---|
| FB-X     | REFERS TO THE MANIFOLD SUPPORT SIZE AND CORRESPONDS TO THE TABLE SHOWN WITH THE SUPPORT DETAIL. |
| RSP-XXXX |   |

INDICATES THE SUPPORT STAND PART NUMBER.
- CONTRACTOR TO CUT PIPE TO SUIT AND SOLVENT WELD AS REQ'D IN THE FIELD.

4					
3					
2					
1					
NO.	DATE	REVISION			BY
NORTHGLENN, CO WWTP					
THIS DRAWING IS THE PROPERTY OF SANITAIRE AND IS SUBMITTED IN CONFIDENCE. IT IS NOT TO BE DISCLOSED, USED OR DUPLICATED WITHOUT PERMISSION OF SANITAIRE.					
AERATION BASINS 2 & 3 DROPLEG/MANIFOLD SECTIONS					
SANITAIRE® BROWN DEER, WISCONSIN 53223 <b>ABJ</b> DRAWN BY MC DATE 4-14-05 LOUPE NEW JOB 04-57505 SHEET 5 OF 10 CHKD BY BB DATE 4-18-05 SFD APP'D BY DATE SIZE D REV. DWG E-5					

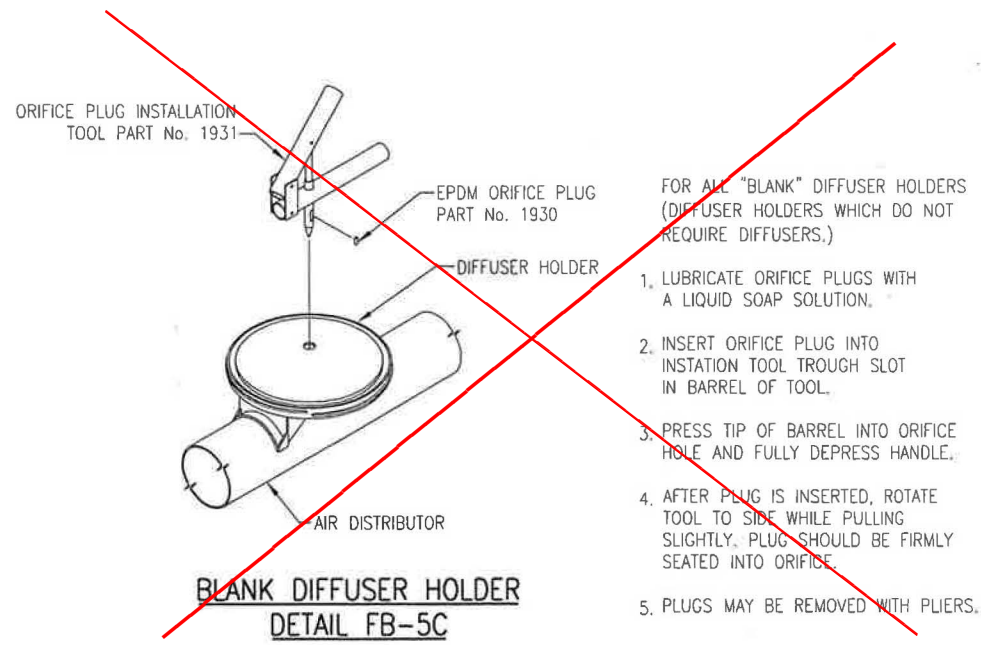
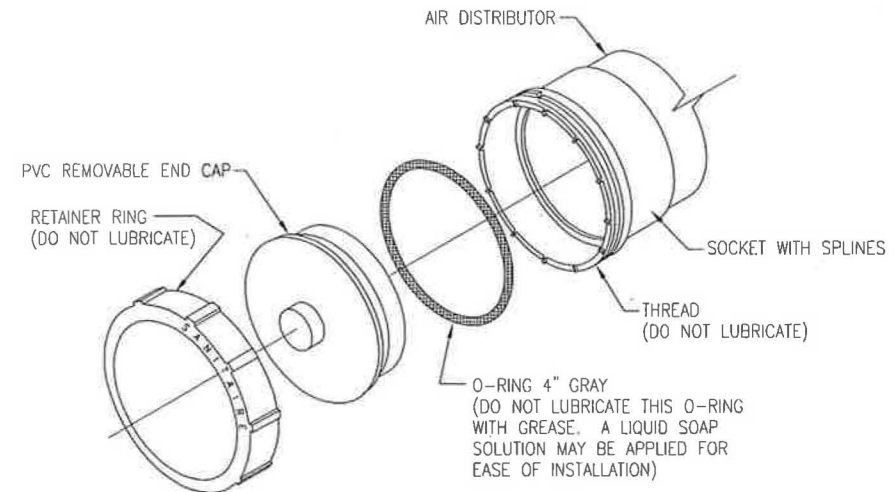
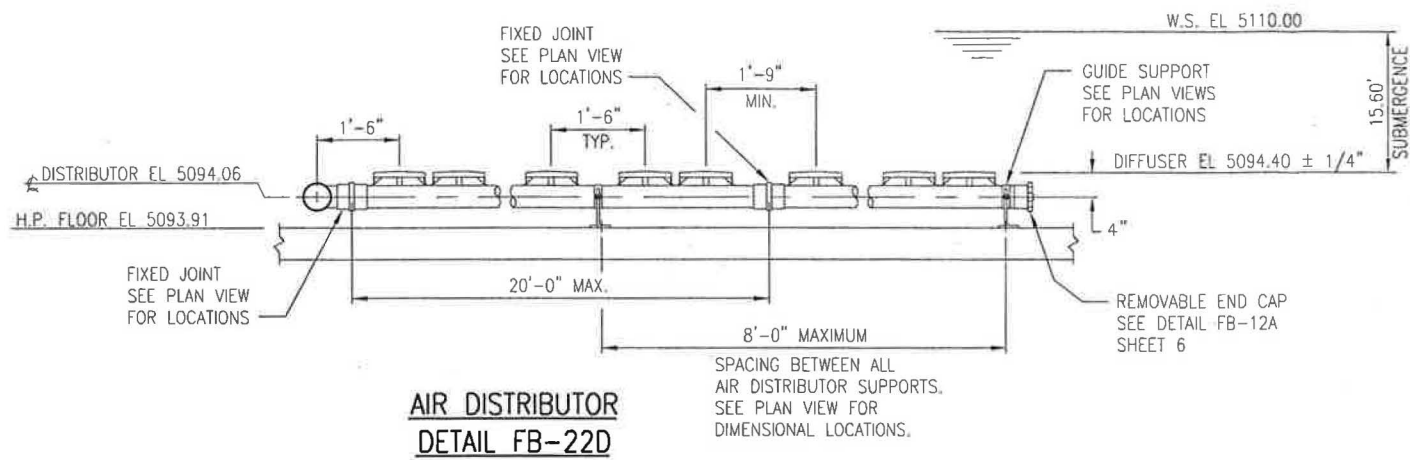

- FOR ALL "BLANK" DIFFUSER HOLDERS (DIFFUSER HOLDERS WHICH DO NOT REQUIRE DIFFUSERS.)
1. LUBRICATE ORIFICE PLUGS WITH A LIQUID SOAP SOLUTION.
  2. INSERT ORIFICE PLUG INTO INSTANTATION TOOL TROUGH SLOT IN BARREL OF TOOL.
  3. PRESS TIP OF BARREL INTO ORIFICE HOLE AND FULLY DEPRESS HANDLE.
  4. AFTER PLUG IS INSERTED, ROTATE TOOL TO SIDE WHILE PULLING SLIGHTLY. PLUG SHOULD BE FIRMLY SEATED INTO ORIFICE.
  5. PLUGS MAY BE REMOVED WITH PLIERS.

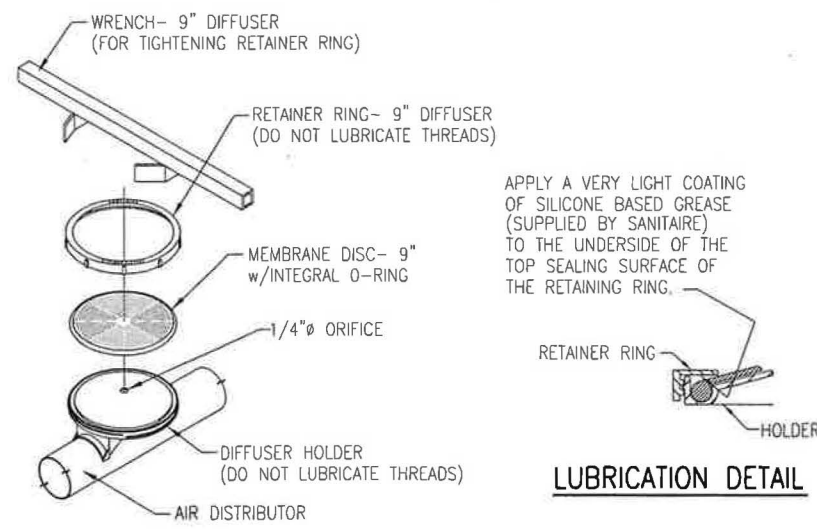

4				
3				
2				
1				
NO.	DATE	REVISION	BY	
NORTHGLENN, CO WWTP				
THIS DRAWING IS THE PROPERTY OF SANITAIRE AND IS SUBMITTED IN CONFIDENCE. IT IS NOT TO BE DISCLOSED, USED OR DUPLICATED WITHOUT PERMISSION OF SANITAIRE.				
TYPICAL DISTRIBUTOR DETAIL & DETAILS				
Sanitaire ITT Industries				
SANITAIRE® BROWN DEER, WISCONSIN 53223 ABJ®				
DRWN BY	MC	DATE	4-14-85	EQUIP. NO.
CHKD BY	BB	DATE	4-18-85	JOB
APP'D BY		DATE		REV.
		DATE		REV.
				04-5750S
				6 OF 10
				C-6

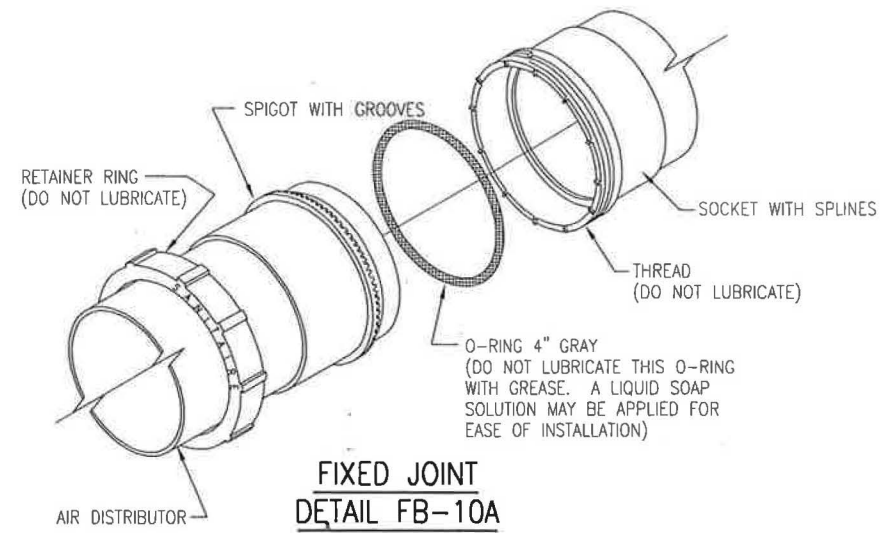

**FIXED JOINT  
DETAIL FB-10A**

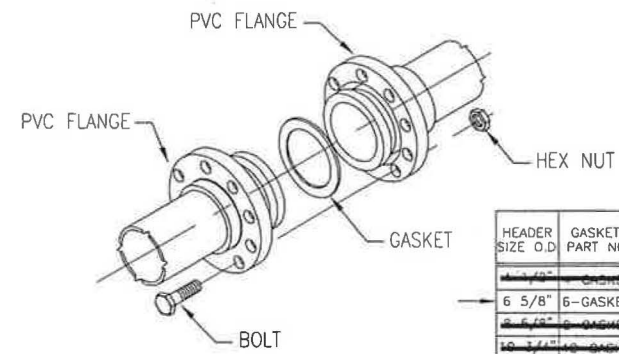

**PVC FLANGE  
DETAIL FB-23**

HEADER SIZE O.D.	GASKET PART NO.	BOLT SIZE	QUAN REQ'D PER FLANGE
4 1/2"	6-GASKET	3/4" x 4"	8
6 5/8"	6-GASKET	3/4" x 4"	8
8 5/8"	6-GASKET	3/4" x 4"	8
10 7/8"	6-GASKET	3/4" x 4"	8
12 3/4"	6-GASKET	3/4" x 4"	8

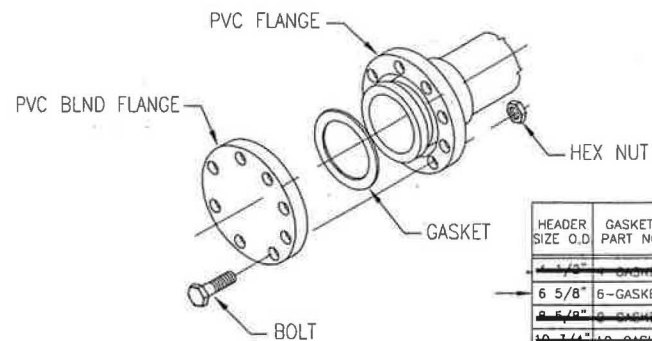

**BLIND FLANGE  
DETAIL NS-1**

HEADER SIZE O.D.	GASKET PART NO.	BOLT SIZE	QUAN REQ'D PER FLANGE
4 1/2"	6-GASKET	3/4" x 4"	8
6 5/8"	6-GASKET	3/4" x 4"	8
8 5/8"	6-GASKET	3/4" x 4"	8
10 7/8"	6-GASKET	3/4" x 4"	8
12 3/4"	6-GASKET	3/4" x 4"	8

4			
3			
2			
1			
NO.	DATE	REVISION	BY

NORTHGLENN, CO  
WWTP

THIS DRAWING IS THE PROPERTY OF SANITAIRE AND IS SUBMITTED IN CONFIDENCE. IT IS NOT TO BE DISCLOSED, USED OR DUPLICATED WITHOUT PERMISSION OF SANITAIRE.

DETAILS

Sanitaire  
ITT Industries  
SANITAIRE® BROWN DEER, WISCONSIN 53223 ABJ®

DRAWN BY	MC	DATE	4-14-05	EQUIP	MEM	JOB	04-5750S	SHEET	7
CHKD BY	BB	DATE	4-18-05	STD				OF	10
APPROV BY		DATE		SIZE	D	REV.	ENG	E-7	



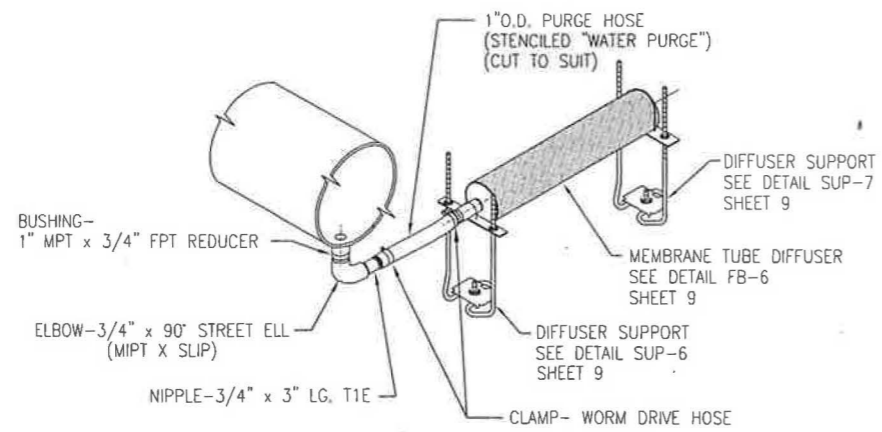

**CONTINUOUS PURGE ASSEMBLY  
DETAIL PURGE-18**

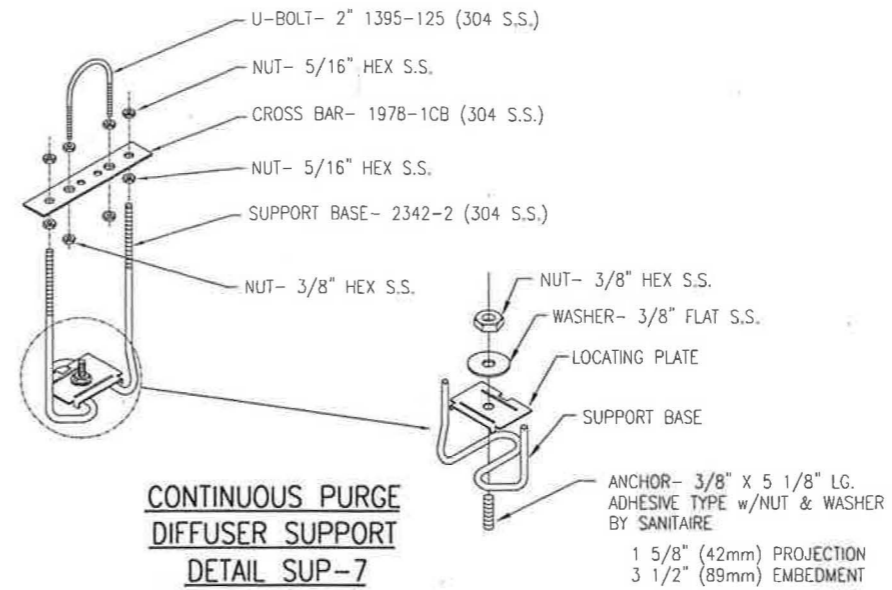

**CONTINUOUS PURGE  
DIFFUSER SUPPORT  
DETAIL SUP-7**

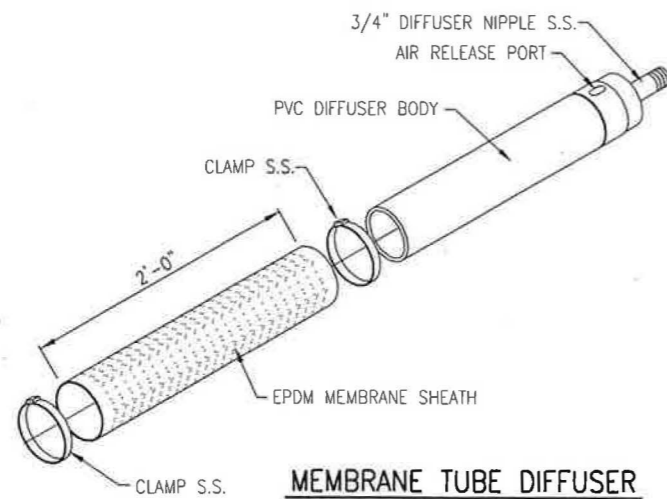

**MEMBRANE TUBE DIFFUSER  
DETAIL FB-6**

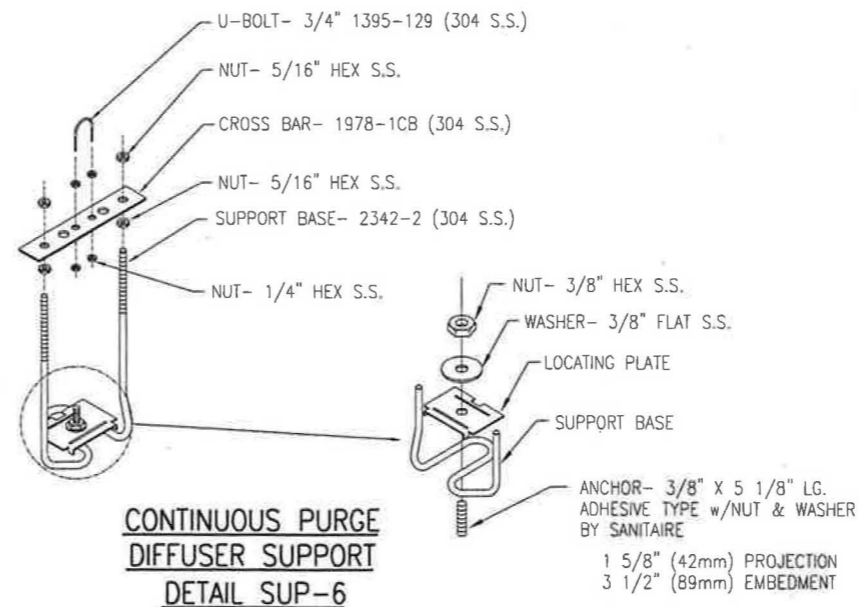

**CONTINUOUS PURGE  
DIFFUSER SUPPORT  
DETAIL SUP-6**

4				
3				
2				
1				
NO.	DATE	REVISION	BY	
NORTHGLENN, CO WWTP				
DETAILS				
Sanitaire ITT Industries				
BROWN DEER, WISCONSIN 53223				
OWNED BY	MC	DATE 4-14-05	EQUIP. MEN	JOB 04-5750S
CHG'D BY	BB	DATE 4-18-05	STB	REV 9
APP'D BY		DATE	SIZE D	REV. ENC C-9
				OF 10



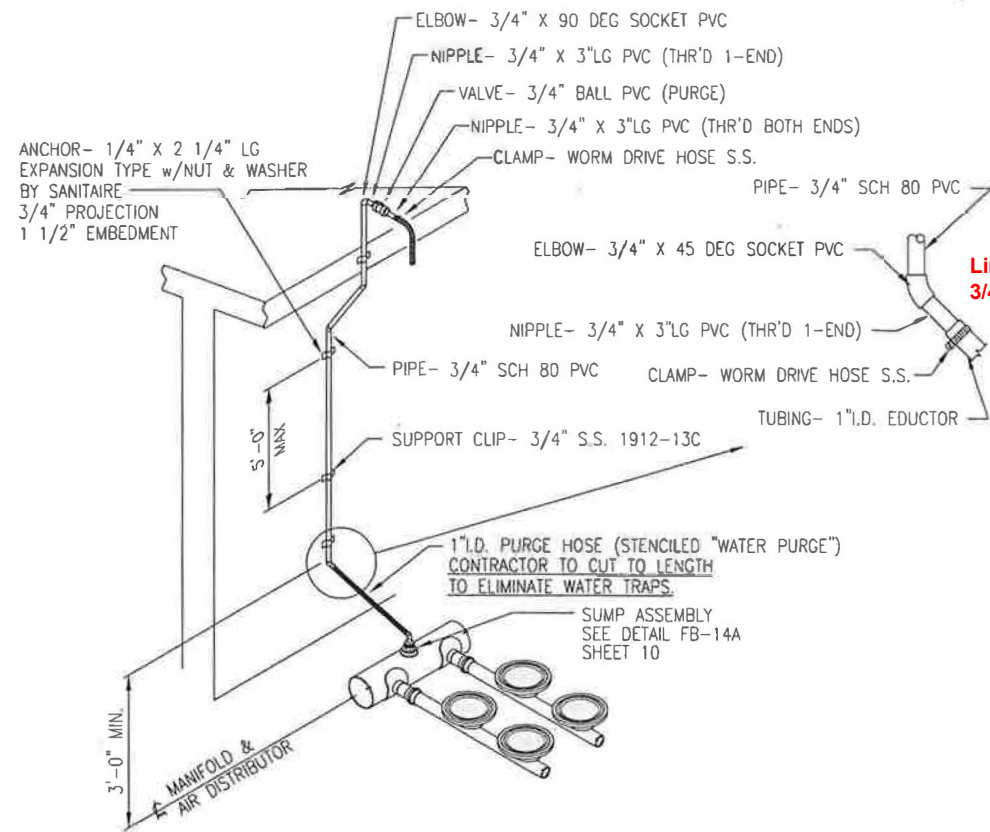

**PURGE SUMP ASSEMBLY**  
**DETAIL PURGE-24**

Limits of construction are below this 3/4 in x 45 degree elbow

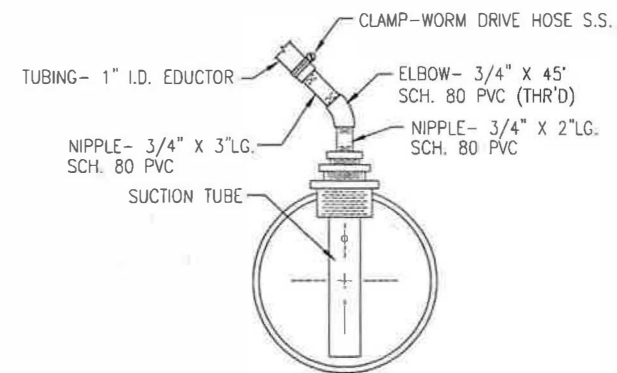

**PURGE SUMP**  
**DETAIL FB-14A**

4			
3			
2			
1			
NO.	DATE	REVISION	BY
NORTHGLENN, CO WWTP			
DETAILS			
DRWN BY	MC	DATE 4-14-05	EQUIP. NEW
CHKD BY	BR	DATE 4-18-05	STD.
APPRD BY		DATE	REV. E-10
		JOB 04-5750S	SHT 10 OF 10

# Section 3 - Data Sheets and Start Up Procedures

## MEMBRANE DISC GRID SYSTEM FINE BUBBLE AERATION EQUIPMENT DATA SHEETS

PROJECT: NORTHGLENN, CO WWTP

SANTIAIRE #: 04-5750S

LOCATION: AERATION BASINS #1 - #3

### DROPLEG

UPPER - BY OTHERS **N.I.C.**

### LOWER

MATERIAL: PVC SIZE: 6" WALL THICKNESS: SCH 40 (0.280")

NUMBER: 2

### MANIFOLD

MATERIAL: PVC SIZE: 6" WALL THICKNESS: SCH 40 (0.280")

NUMBER: 2

### AIR DISTRIBUTOR

MATERIAL: PVC SDR 17.8 SIZE: 4.215" O.D. WALL THICKNESS: 0.237"

### PURGE

MATERIAL: PVC

STYLE: STANDARD AND CONTINUOUS, 1 EACH/GRID

### SUPPORTS

MATERIAL: 304 STAINLESS STEEL

### ANCHORS

MATERIAL: 304 STAINLESS STEEL

MANIFOLD TYPE: HILTI ADHESIVE SIZE: 1/2"

HEADER TYPE: HILTI EXPANSION SIZE: 3/8"

DATE: JANUARY 6, 2005

R.1 APRIL 18, 2005

SHEET 1 OF 2

DIFFUSERS – SILVER SERIES II

MATERIAL: EPDM EFFECTIVE AREA: 0.41FT<sup>2</sup>

(1) 1/4" DIAMETER; DIFFUSER ORIFICE SHOP DRILLED

GRID INFORMATION

GRID TYPE	NO. OF GRIDS	DISTRIB. PER GRID	HOLDERS PER DISTRIB.	TOTAL HOLDERS PER GRID	TOTAL DIFFUSERS INSTALLED PER GRID	TOTAL DIFFUSERS THIS GRID TYPE
1	9	10	33	330	<del>300</del> <b>330</b>	<del>2,700</del> <b>2,970</b>

ADDITIONALLY, SANITAIRE WILL PROVIDE THE FOLLOWING:

(135) MEMBRANE DISC DIFFUSERS

(135) DIFFUSER RETAINER RINGS

~~(14) BLANK DIFFUSER PLUGS~~

**Sanitaire**

---



**ITT Industries**



**Diffused Aeration Equipment**

for

**Northglenn, CO WWTP  
Aeration Basins #1 - #3**

Prepared For:

**Integra Engineering**

450 Decatur St  
Denver, CO 80204  
303 825-1802

Water Control Corporation  
2460 W. 26th Avenue  
Suite 215C  
Denver, CO 80211-5359  
303 477-1970

Sanitaire #04-5750S  
March 22, 2005

fm J:\04-5750S\ENGINEERING\5750s-AB's 1.aer

## Sanitaire Aeration Design Inputs for: Northglenn, CO WWTP, Sanitaire #04-5750S

### Tank Geometry

3 Trains Each Consisting of:

Parameter	Units	Pass 1
Parallel Reactors		1
Pass Process		Aerobic
SWD	ft	16.4
Submergence	ft	15.6
Volume	ft <sup>3</sup>	87,689.6
Reactor Geometry:		Rect
Length	ft	134.0
Width	ft	40.0

### Oxygen/Air Distribution

	Zone	1
	Pass	1
Default		100.0%

### Oxygenation

Parameter	Units	Min SOR	Design SOR	Max SOR	Design Airflow
No. Trains Operating		3	3	3	3
Air Rate	scfm				4,870.0
Oxygen Requirement	lb/day	15,500.0-S	32,900.0-S	46,020.0-S	

### Standard Oxygen Correction Factor Parameters

Parameter	Units	Min SOR	Design SOR	Max SOR	Design Airflow
Site Elevation	FASL	5100	5100	5100	5100
Ambient Pressure	PSIA	12.26	12.26	12.26	12.26
Water Temperature	°C	<b>20</b>	<b>20</b>	<b>20</b>	<b>20</b>

Notes:

***Bold, Italicized*** text indicate assumptions made by Sanitaire

A - Indicates Actual (AOR) Requirement.

S - Indicates Standard Condition (SOR) Oxygen requirement.

If the AOR/SOR parameter is not given, then its value will be evaluated later if suitable alpha, beta, D.O., theta, pressure, and temperature data is supplied.

Round tanks are evaluated as rectangular tanks diameter equal to length and equal surface area.

Annular tanks are evaluated as rectangular tanks of width equal to the annular width and equal surface area.

**Sanitaire Project Name: Northgletghlenn, CO WWTP**  
**Sanitaire Project #04-5750S** 04-5750S  
**Design Summary**

	Units	Operating Point & O2 Distribution			
		Min SOR Default	Design SOR Default	Max SOR Default	Design Airflow Default
No. Trains in Operation		3	3	3	3
No. Grids in Operation		9	9	9	9
No. Operating Diffusers		2,700	2,700	2,700	2,700
SOR	lb/day	15,500	32,900	46,020	37,720
SOTE	%	34.5	31.4	30.2	30.9
Total Air Rate	scfm	1,792	4,176	6,090	4,870
Min. Diffuser Air Rate	scfm/diff.	0.66	1.55	2.26	1.8
Max. Diffuser Air Rate	scfm/diff.	0.66	1.55	2.26	1.8
Static Pressure	psig	6.76	6.76	6.76	6.76
Diffuser DWP @ Min Air	psig	0.45	0.52	0.58	0.54
Diffuser DWP @ Max Air	psig	0.45	0.52	0.58	0.54
Pressure @ Top of Dropleg	psig	7.22	7.35	7.49	7.4
Est. Blower Efficiency		70%	70%	70%	70%
Est. Motor Efficiency		90%	90%	90%	90%
BHP		71.76	169.7	251.4	199.0
Est. Motor Electrical Load	kW	59.48	140.7	208.4	164.9
Est. Standard Aeration Efficiency	#SOR/BHP-hr	9.00	8.08	7.63	7.90

**Notes:**

- (1) Fine Mixing air based on 0.00 scfm/ft<sup>2</sup>
- (2) Design air is the maximum of process air or mixing air
- (3) Delivered oxygen based on design air
- (4) Brake Horsepower based on adiabatic compression, 70% mechanical efficiency and 0.30 psi line loss
- (5) Performance based on diffuser density (A1/Ad), submergence, and diffuser unit air flow.
- (6) Blower Pressure Capability also requires consideration of:
  - A. The Air Main headloss (piping, fittings, valves, instrumentation, etc.) between the blower and the aeration assembly dropleg connections.
  - B. Potential for increased headloss resulting from diffuser fouling and/or aging. Please refer to the US EPA Fine Pore Design Manual (EPA/625/1-89/023), WEF Manual of Practice FD-13, and other technical publications for a detailed discussion on this subject. Note that this headloss consideration relates to all Fine Pore systems regardless of supplier or type of diffuser element.
  - C. Increased diffuser submergence during Peak Flow conditions.
- (7) Air Flow defined at 20 °C

**Sanitaire Project Name: Northglenn, CO WWTP**

**Sanitaire Project #04-5750S**

Consulting Engineer: Integra Engineering  
 Operating Condition: Min SOR  
 Oxygen Distribution: Default

**Aeration System Design**

Parameter	Units	Zone 1	Totals/Overall
Pass		1	
SWD	ft	16.36	
Subm	ft	15.61	
Volume	ft <sup>3</sup>	87,689.6	263,068.8
No. Parallel Tanks		1	
No. Trains in Operation		3	
Grid Count		3	9
Dropleg Diameter	inches	6	
At/Ad		14.53	
Diffuser Density	% Floor	6.88%	
Diffusers/Grid		300	2,700

**Oxygen Transfer**

Diffuser Type		SSII-9	
Alpha			
Beta			
Theta			
D.O.	mg/l		
Water Temp	°C	20	
AOR/SOR			
Oxygen Distribution	%/Zone	100.0%	100.0%
AOR	lb/day		
SOR	lb/day	15,500.0	15,500.0
Air Rate (8)	scfm		

**Performance**

Mixing Criteria	scfm/ft <sup>2</sup>		
Safety Factor	%		
Mixing Air (1)	scfm		
Process Air (for SOR)	scfm	1,792.0	
Design Air (2,8)	scfm	1,792.0	1,792.0
Diffuser Air Rate	scfm/Diff.	0.66	0.66
Delivered SOR	lb/day	15,500.1	15,500.1
Delivered SOTE	%	34.5%	34.5%
Pressure @ Top of Dropleg	psig	7.22	7.22
Bhp		71.8	71.8

**Notes:**

- (1) Fine Mixing air based on 0.00 scfm/ft<sup>2</sup>
- (2) Design air is the maximum of process air or mixing air
- (3) Delivered oxygen based on design air
- (4) Brake Horsepower based on adiabatic compression, 70% mechanical efficiency and 0.30 psi line loss
- (5) Performance based on diffuser density (At/Ad), submergence, and diffuser unit air flow.
- (6) Diffuser Air Flow based on Active Valve Modulation
- (7) Blower Pressure Capability also requires consideration of:
  - A. The Air Main headloss (piping, fittings, valves, instrumentation, etc.) between the blower and the aeration assembly dropleg connections.
  - B. Potential for increased headloss resulting from diffuser fouling and/or aging. Please refer to the US EPA Fine Pore Design Manual (EPA/625/1-89/023), WEF Manual of Practice FD-13, and other technical publications for a detailed discussion on this subject. Note that this headloss consideration relates to all Fine Pore systems regardless of supplier or type of diffuser element.
  - C. Increased diffuser submergence during Peak Flow conditions.
- (8) Air Flow defined at 20 °C

**Sanitaire Project Name: Northglenn, CO WWTP**

**Sanitaire Project #04-5750S**

Consulting Engineer: Integra Engineering  
 Operating Condition: Design SOR  
 Oxygen Distribution: Default

**Aeration System Design**

Parameter	Units	Zone 1	Totals/Overall
Pass		1	
SWD	ft	16.36	
Subm	ft	15.61	
Volume	ft <sup>3</sup>	87,689.6	263,068.8
No. Parallel Tanks		1	
No. Trains in Operation		3	
Grid Count		3	9
Dropleg Diameter	inches	6	
At/Ad		14.53	
Diffuser Density	% Floor	6.88%	
Diffusers/Grid		300	2,700

**Oxygen Transfer**

Diffuser Type		SSII-9	
Alpha			
Beta			
Theta			
D.O.	mg/l		
Water Temp	°C	20	
AOR/SOR			
Oxygen Distribution	%/Zone	100.0%	100.0%
AOR	lb/day		
SOR	lb/day	32,900.0	32,900.0
Air Rate (8)	scfm		

**Performance**

Mixing Criteria	scfm/ft <sup>2</sup>		
Safety Factor	%		
Mixing Air (1)	scfm		
Process Air (for SOR)	scfm	4,176.1	
Design Air (2,8)	scfm	4,176.1	4,176.1
Diffuser Air Rate	scfm/Diff.	1.55	1.55
Delivered SOR	lb/day	32,899.9	32,899.9
Delivered SOTE	%	31.4%	31.4%
Pressure @ Top of Dropleg	psig	7.35	7.35
Bhp		169.7	169.7

**Notes:**

- (1) Fine Mixing air based on 0.00 scfm/ft<sup>2</sup>
- (2) Design air is the maximum of process air or mixing air
- (3) Delivered oxygen based on design air
- (4) Brake Horsepower based on adiabatic compression, 70% mechanical efficiency and 0.30 psi line loss
- (5) Performance based on diffuser density (At/Ad), submergence, and diffuser unit air flow.
- (6) Diffuser Air Flow based on Active Valve Modulation
- (7) Blower Pressure Capability also requires consideration of:
  - A. The Air Main headloss (piping, fittings, valves, instrumentation, etc.) between the blower and the aeration assembly dropleg connections.
  - B. Potential for increased headloss resulting from diffuser fouling and/or aging. Please refer to the US EPA Fine Pore Design Manual (EPA/625/1-89/023), WEF Manual of Practice FD-13, and other technical publications for a detailed discussion on this subject. Note that this headloss consideration relates to all Fine Pore systems regardless of supplier or type of diffuser element.
  - C. Increased diffuser submergence during Peak Flow conditions.
- (8) Air Flow defined at 20 °C



**Sanitaire Project Name: Northglenn, CO WWTP**

**Sanitaire Project #04-5750S**

Consulting Engineer: Integra Engineering  
 Operating Condition: Max SOR  
 Oxygen Distribution: Default

**Aeration System Design**

Parameter	Units	Zone 1	Totals/Overall
Pass		1	
SWD	ft	16.36	
Subm	ft	15.61	
Volume	ft <sup>3</sup>	87,689.6	263,068.8
No. Parallel Tanks		1	
No. Trains in Operation		3	
Grid Count		3	9
Dropleg Diameter	inches	6	
At/Ad		14.53	
Diffuser Density	% Floor	6.88%	
Diffusers/Grid		300	2,700

**Oxygen Transfer**

Diffuser Type		SSII-9	
Alpha			
Beta			
Theta			
D.O.	mg/l		
Water Temp	°C	20	
AOR/SOR			
Oxygen Distribution	%/Zone	100.0%	100.0%
AOR	lb/day		
SOR	lb/day	46,020.0	46,020.0
Air Rate (8)	scfm		

**Performance**

Mixing Criteria	scfm/ft <sup>2</sup>		
Safety Factor	%		
Mixing Air (1)	scfm		
Process Air (for SOR)	scfm	6,090.0	
Design Air (2,8)	scfm	6,090.0	6,090.0
Diffuser Air Rate	scfm/Diff.	2.26	2.26
Delivered SOR	lb/day	46,019.6	46,019.6
Delivered SOTE	%	30.2%	30.2%
Pressure @ Top of Dropleg	psig	7.49	7.49
Bhp		251.4	251.4

**Notes:**

- (1) Fine Mixing air based on 0.00 scfm/ft<sup>2</sup>
- (2) Design air is the maximum of process air or mixing air
- (3) Delivered oxygen based on design air
- (4) Brake Horsepower based on adiabatic compression, 70% mechanical efficiency and 0.30 psi line loss
- (5) Performance based on diffuser density (At/Ad), submergence, and diffuser unit air flow.
- (6) Diffuser Air Flow based on Active Valve Modulation
- (7) Blower Pressure Capability also requires consideration of:
  - A. The Air Main headloss (piping, fittings, valves, instrumentation, etc.) between the blower and the aeration assembly dropleg connections.
  - B. Potential for increased headloss resulting from diffuser fouling and/or aging. Please refer to the US EPA Fine Pore Design Manual (EPA/625/1-89/023), WEF Manual of Practice FD-13, and other technical publications for a detailed discussion on this subject. Note that this headloss consideration relates to all Fine Pore systems regardless of supplier or type of diffuser element.
  - C. Increased diffuser submergence during Peak Flow conditions.
- (8) Air Flow defined at 20 °C

**Sanitaire Project Name: Northglenn, CO WWTP**

**Sanitaire Project #04-5750S**

Consulting Engineer: Integra Engineering  
 Operating Condition: Design Airflow  
 Oxygen Distribution: Default

**Aeration System Design**

Parameter	Units	Zone 1	Totals/Overall
Pass		1	
SWD	ft	16.36	
Subm	ft	15.61	
Volume	ft <sup>3</sup>	87,689.6	263,068.8
No. Parallel Tanks		1	
No. Trains in Operation		3	
Grid Count		3	9
Dropleg Diameter	inches	6	
At/Ad		14.53	
Diffuser Density	% Floor	6.88%	
Diffusers/Grid		300	2,700

**Oxygen Transfer**

Diffuser Type		SSII-9	
Alpha			
Beta			
Theta			
D.O.	mg/l		
Water Temp	°C	20	
AOR/SOR			
Oxygen Distribution	%/Zone	100.0%	100.0%
AOR	lb/day		
SOR	lb/day		
Air Rate (8)	scfm	4,870.0	4,870.0

**Performance**

Mixing Criteria	scfm/ft <sup>2</sup>		
Safety Factor	%		
Mixing Air (1)	scfm		
Process Air (for SOR)	scfm	4,870.0	
Design Air (2,8)	scfm	4,870.0	4,870.0
Diffuser Air Rate	scfm/Diff.	1.80	1.80
Delivered SOR	lb/day	37,720.5	37,720.5
Delivered SOTE	%	30.9%	30.9%
Pressure @ Top of Dropleg	psig	7.40	7.40
Bhp		199.0	199.0

**Notes:**

- (1) Fine Mixing air based on 0.00 scfm/ft<sup>2</sup>
- (2) Design air is the maximum of process air or mixing air
- (3) Delivered oxygen based on design air
- (4) Brake Horsepower based on adiabatic compression, 70% mechanical efficiency and 0.30 psi line loss
- (5) Performance based on diffuser density (At/Ad), submergence, and diffuser unit air flow.
- (6) Diffuser Air Flow based on Active Valve Modulation
- (7) Blower Pressure Capability also requires consideration of:
  - A. The Air Main headloss (piping, fittings, valves, instrumentation, etc.) between the blower and the aeration assembly dropleg connections.
  - B. Potential for increased headloss resulting from diffuser fouling and/or aging. Please refer to the US EPA Fine Pore Design Manual (EPA/625/1-89/023), WEF Manual of Practice FD-13, and other technical publications for a detailed discussion on this subject. Note that this headloss consideration relates to all Fine Pore systems regardless of supplier or type of diffuser element.
  - C. Increased diffuser submergence during Peak Flow conditions.
- (8) Air Flow defined at 20 °C

**Sanitaire Project Name: Northglenn** Northglenn, CO WWTP

**Sanitaire Project #04-5750S** 04-5750S

**Headloss Summary by System Operating Point**

Consulting Engineer: Integra Engineering

Operating Condition: Min SOR

Oxygen Distribution: Default

**Grid Design**

	Units	Grid 1
Diffuser Count		300
Dropleg Diameter	inches	6
Line Count		10
Line Spacing	ft	4.00
Manifold Diameter	inches	6
Manifold Length	ft	36.00
Header Length	ft	39.75
Manifold Location		End
Manifold Elevation		Inline
Dropleg Location		End
Header Orientation		Width

**Grid Pressure**

Grid Air Flow	scfm	199.1
Diffuser Air Flow	scfm	0.66
Submergence	ft	15.61
Orifice Diameter	inches	1/4
Static Header Pressure Differential in Assembly	psig	2.03E-03
Average Header Pressure in Assembly	PSI	7.16
A: Average Headloss from Top of Dropleg To Headers	PSI	3.26E-03
B: Diffuser Orifice Headloss	psi	8.97E-03
C: Diffuser Dynamic Wet Pressure	psi	4.49E-01
D: Static Pressure	psig	6.76
Total Pressure Required at Top of Dropleg (A+B+C+D)	psig	7.22
Friction Headloss (A+B)	PSI	1.22E-02

**Sanitaire Project Name: Northglenn** Northglenn, CO WWTP

**Sanitaire Project #04-5750S** 04-5750S

**Headloss Summary by System Operating Point**

Consulting Engineer: Integra Engineering

Operating Condition: Design SOR

Oxygen Distribution: Default

**Grid Design**

	Units	Grid 1
Diffuser Count		300
Dropleg Diameter	inches	6
Line Count		10
Line Spacing	ft	4.00
Manifold Diameter	inches	6
Manifold Length	ft	36.00
Header Length	ft	39.75
Manifold Location		End
Manifold Elevation		Inline
Dropleg Location		End
Header Orientation		Width

**Grid Pressure**

Grid Air Flow	scfm	464.0
Diffuser Air Flow	scfm	1.55
Submergence	ft	15.61
Orifice Diameter	inches	1/4
Static Header Pressure Differential in Assembly	psig	1.10E-02
Average Header Pressure in Assembly	PSI	7.14
A: Average Headloss from Top of Dropleg To Headers	PSI	1.77E-02
B: Diffuser Orifice Headloss	psi	5.08E-02
C: Diffuser Dynamic Wet Pressure	psi	5.23E-01
D: Static Pressure	psig	6.76
Total Pressure Required at Top of Dropleg (A+B+C+D)	psig	7.35
Friction Headloss (A+B)	PSI	6.86E-02

**Sanitaire Project Name: Northglenn** Northglenn, CO WWTP

**Sanitaire Project #04-5750S** 04-5750S

**Headloss Summary by System Operating Point**

Consulting Engineer: Integra Engineering

Operating Condition: Max SOR

Oxygen Distribution: Default

**Grid Design**

	Units	Grid 1
Diffuser Count		300
Dropleg Diameter	inches	6
Line Count		10
Line Spacing	ft	4.00
Manifold Diameter	inches	6
Manifold Length	ft	36.00
Header Length	ft	39.75
Manifold Location		End
Manifold Elevation		Inline
Dropleg Location		End
Header Orientation		Width

**Grid Pressure**

Grid Air Flow	scfm	676.7
Diffuser Air Flow	scfm	2.26
Submergence	ft	15.61
Orifice Diameter	inches	1/4
Static Header Pressure Differential in Assembly	psig	2.35E-02
Average Header Pressure in Assembly	PSI	7.12
A: Average Headloss from Top of Dropleg To Headers	PSI	3.78E-02
B: Diffuser Orifice Headloss	psi	1.10E-01
C: Diffuser Dynamic Wet Pressure	psi	5.82E-01
D: Static Pressure	psig	6.76
Total Pressure Required at Top of Dropleg (A+B+C+D)	psig	7.49
Friction Headloss (A+B)	PSI	1.48E-01

**Sanitaire Project Name: Northglenn** Northglenn, CO WWTP

**Sanitaire Project #04-5750S** 04-5750S

**Headloss Summary by System Operating Point**

Consulting Engineer: Integra Engineering

Operating Condition: Design Airflow

Oxygen Distribution: Default

**Grid Design**

	Units	Grid 1
Diffuser Count		300
Dropleg Diameter	inches	6
Line Count		10
Line Spacing	ft	4.00
Manifold Diameter	inches	6
Manifold Length	ft	36.00
Header Length	ft	39.75
Manifold Location		End
Manifold Elevation		Inline
Dropleg Location		End
Header Orientation		Width

**Grid Pressure**

Grid Air Flow	scfm	541.1
Diffuser Air Flow	scfm	1.80
Submergence	ft	15.61
Orifice Diameter	inches	1/4
Static Header Pressure Differential in Assembly	psig	1.50E-02
Average Header Pressure in Assembly	PSI	7.13
A: Average Headloss from Top of Dropleg To Headers	PSI	2.41E-02
B: Diffuser Orifice Headloss	psi	6.97E-02
C: Diffuser Dynamic Wet Pressure	psi	5.44E-01
D: Static Pressure	psig	6.76
Total Pressure Required at Top of Dropleg (A+B+C+D)	psig	7.40
Friction Headloss (A+B)	PSI	9.38E-02

**NORTHGLENN, CO - WWTP: AERATION BASINS , with 9 inch Merhrane Disc (WE style) diffusers, 1/4 inch orifice.**

orifice (in-water)	Air/diffuser (SCFM)	Clean DWP (in-water)
0.1	0.42	11.89
1	1.29	13.90
2	1.81	15.09
3	2.20	16.00
4	2.53	16.77
5	2.83	17.44
6	3.09	18.04
7	3.33	18.60
8	3.55	19.11
9	3.77	19.59
10	3.96	20.05
11	4.15	20.48
12	4.33	20.89
13	4.51	21.29
14	4.67	21.67
15	4.83	22.03
16	4.99	22.38
17	5.14	22.73
18	5.28	23.06
19	5.42	23.38
20	5.56	23.69
21	5.69	24.00
22	5.82	24.30
23	5.95	24.59
24	6.08	24.87
25	6.20	25.15

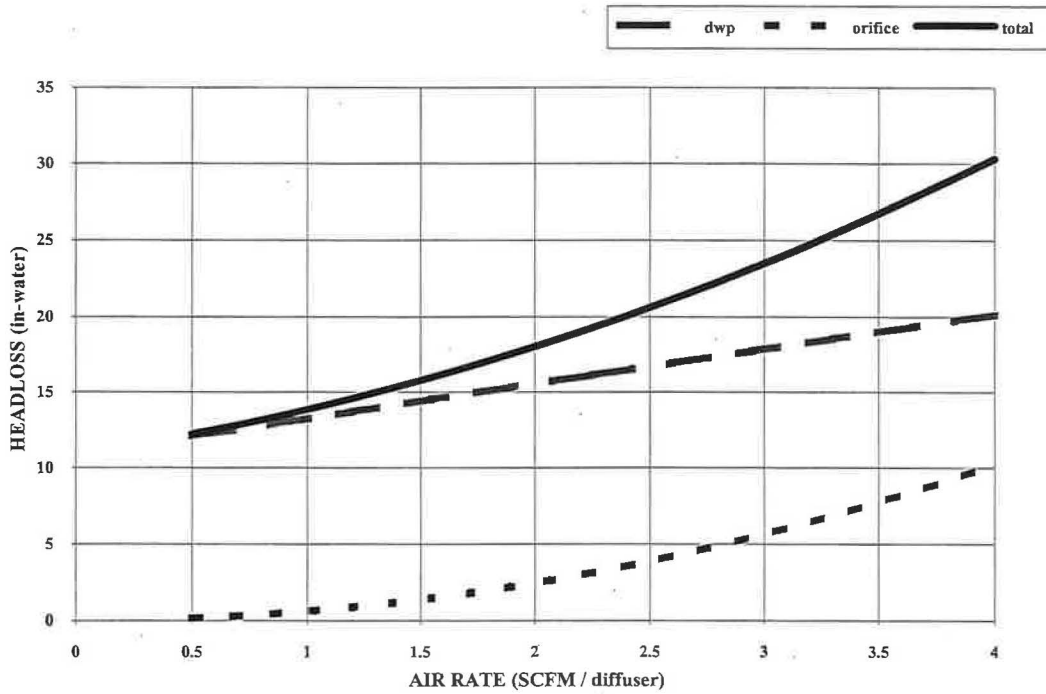

## SANITAIRE CERTIFIED OTE TEST DATA

### 9 inch Silver Series II Membrane Disc (0.41 sqft/Disc)

TARGET: At/Ad = 14.52 (+- 8%). Submergence = 15.30 (ft.) (+-8%), Water Depth = 16.10 (ft.).

TEST	RUN	Data Subm. (feet)	At/Ad	Data Air per Diff. (SCFM)	Data SOTE (%)	Subm. Corrected SOTE (%)
51	A1	16.000	13.955	<b>1.008</b>	33.10	<b>31.65</b>
51	A3	16.000	13.955	<b>1.008</b>	35.10	<b>33.56</b>
51	A2	16.000	13.955	<b>1.011</b>	32.90	<b>31.46</b>
76	B3	15.300	13.578	<b>1.100</b>	33.60	<b>33.60</b>
76	B1	15.300	13.578	<b>1.103</b>	33.00	<b>33.00</b>
76	B2	15.300	13.578	<b>1.103</b>	32.90	<b>32.90</b>
99	A3	15.810	14.354	<b>2.237</b>	32.55	<b>31.50</b>
99	A1	15.810	14.354	<b>2.254</b>	31.27	<b>30.26</b>
99	A2	15.810	14.354	<b>2.289</b>	31.35	<b>30.34</b>
104	C1	16.000	15.224	<b>2.306</b>	36.51	<b>34.91</b>
104	B1	16.000	15.224	<b>2.882</b>	34.67	<b>33.15</b>
104	A3	16.000	15.224	<b>3.403</b>	33.94	<b>32.46</b>
104	A2	16.000	15.224	<b>3.409</b>	33.52	<b>32.05</b>
104	A1	16.000	15.224	<b>3.418</b>	31.56	<b>30.18</b>

**SOTE(corr) = [ SUBM(target) / SUBM(data) ] x SOTE(data).**

**SCFM/KCF=[(SCFM/Disc)1000] / [ AtAd(sqft/Disc)WaterDepth]**

**BOLD** values indicated the data plotted on the attached graph.



## **SANITAIRE CERTIFIED OTE TEST DATA**

### **9 inch Silver Series II Membrane Disc (0.41 sqft/Disc)**

**TARGET: At/Ad = 14.52 (+- 8%). Submergence = 15.30 (ft.) (+-8%), Water Depth = 16.10 (ft.).**

#### **INDEX OF SELECTED CERTIFIED OXYGEN TRANSFER TESTS:**

<b>Test</b>	<b>Date</b>	<b>Job #</b>	<b>Job Name</b>
51	May-01	01-4655	Horry County, SC ("Grand Strand")- RJD
76	Oct-02	02-5042	Trophy Club WWTP - Lancaster, TX
99	Aug-03	Parts	South Windsor, New South Wales, Australia
104	Oct-03	02-5316	Berthoud, County WWTP

**SANITAIRE 9 inch Silver Series II Membrane Disc Diffusers,  
 Experimental Data vs. Factory Performance Characteristic:  
 At/Ad=14.5, Data Normalized To 15.3 Ft. Submergence.**

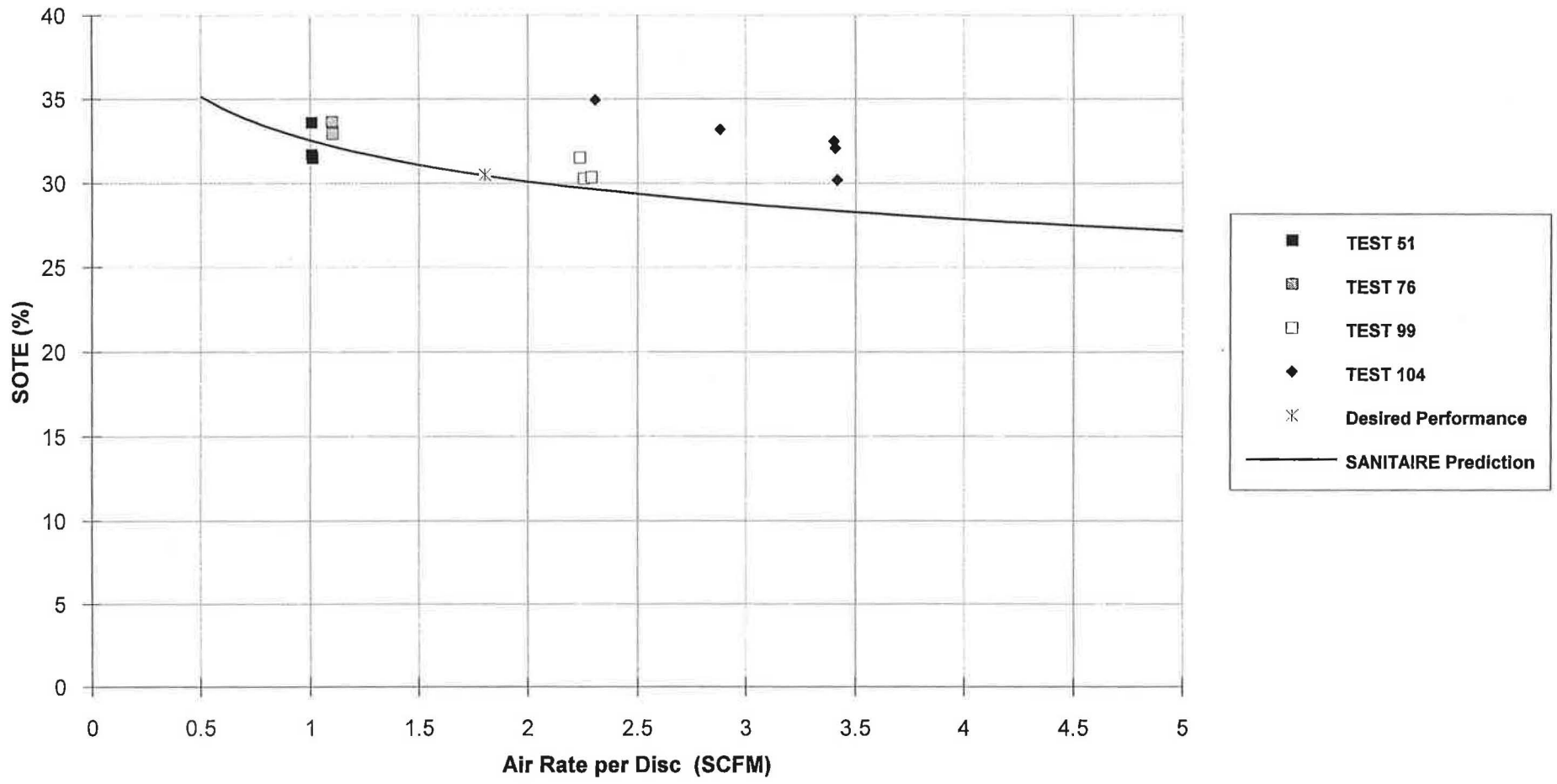

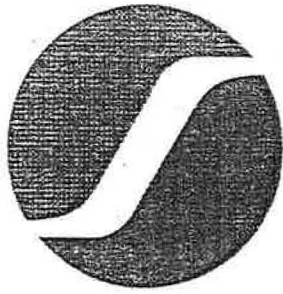

**SANITAIRE®**

**Fine Bubble Aeration System**

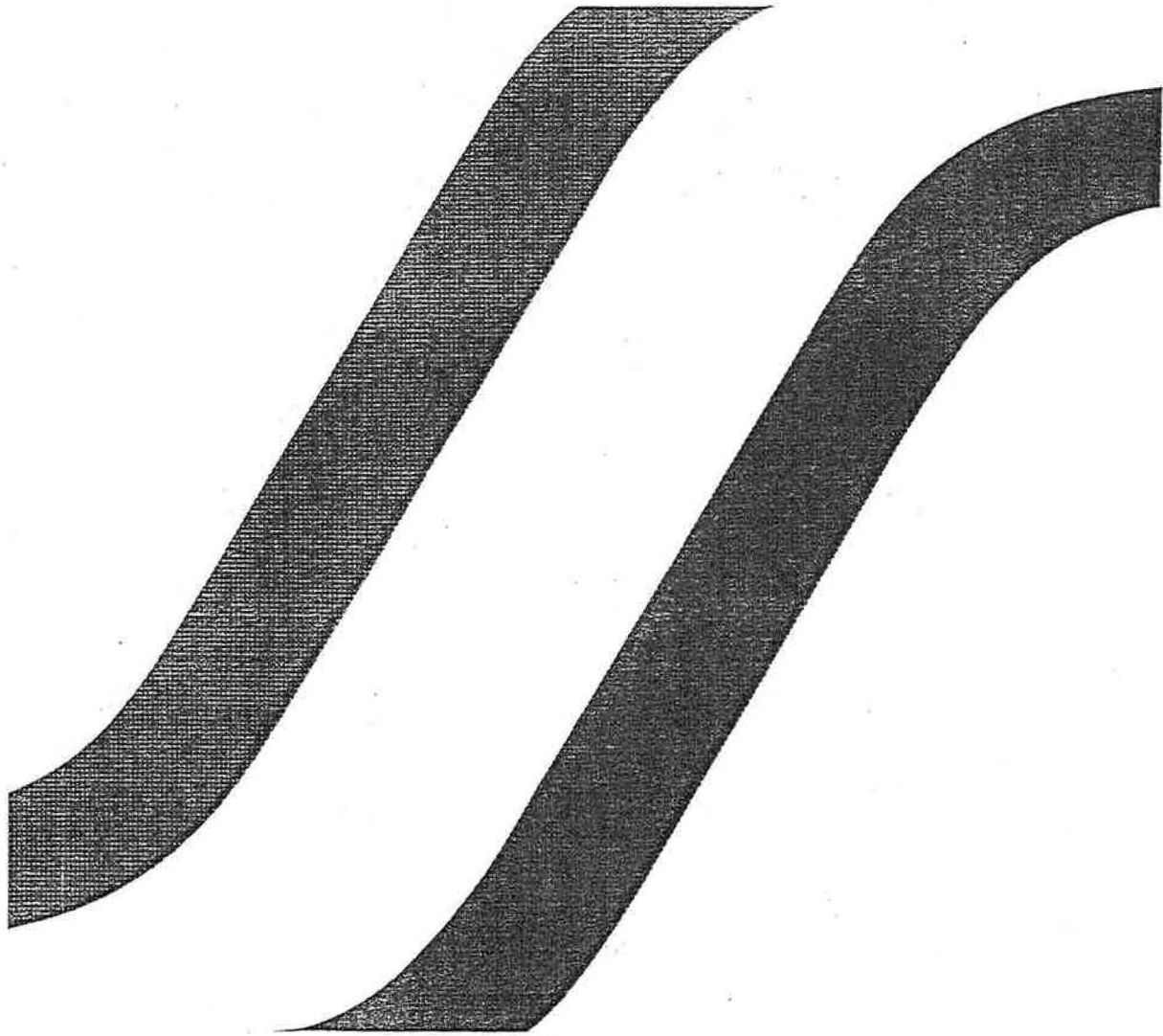

**INSTALLATION, OPERATION AND  
MAINTENANCE MANUAL**

# TABLE OF CONTENTS

	Page No.		Page No.
<b>INTRODUCTION</b> .....	ii	<b>LONG TERM STORAGE PROCEDURES</b> .....	29
<b>INSTALLATION AND START-UP</b>		<b>PIPE REPAIR PROCEDURES</b>	
Receiving and Site Storage.....	1	Manifold Repair — Air Distributor Connection Saddle Replacement on a 3-Piece Fabricated Saddle Assembly .....	31
Physical Inventory.....	1	Manifold Repair — Spigot & Retaining Ring Air Distributor Connection on a 3-Piece Fabricated Saddle Assembly .....	32
Dropleg and Manifold Installation .....	2	Manifold Repair — Air Distributor Connection Saddle Replacement on a 1-Piece Molded Saddle Assembly .....	33
Air Distributor and Drainline Installation .....	7	Manifold Repair — Socket Air Distributor Connection on a 1-Piece Molded Saddle Assembly, 6" Ø - 10" Ø (150-250 mm Ø) Manifolds .....	34
Purge System Installation.....	12	Manifold Repair — Socket Air Distributor Connection on a 1-Piece Molded Saddle Assembly, 12" Ø (300 mm Ø) Manifolds .....	35
Diffuser Installation .....	13	Manifold Repair — Cracked Manifold Pipe Section.....	36
Blank Diffuser Site Orifice Plug Installation.....	15	Manifold Repair — Misaligned Air Distributor Connection .....	37
Aeration System Start-Up Procedure.....	15	Air Distributor Repair — Damaged Fixed Joint Spigot End, Socket End or Expansion Joint Socket End.....	38
<b>PLANT OPERATION</b>		Manifold Repair — Pin Hole Leak Around the Edge of Air Distributor Saddle Connection ..	39
Principles .....	19	Air Distributor Repair — Damaged Fixed Joint Retaining Ring .....	39
Diffuser Operating Air Flow Range .....	19	Air Distributor Repair — Damaged Diffuser Holder or Pipe Section and Obstacle, Pipe Re-routing Requirements.....	40, 41
Mixing, D.O. Levels and Minimum Diffuser Air Flow Rates.....	20		
Diffuser Fouling.....	20		
<b>PREVENTATIVE MAINTENANCE</b>			
Moisture Purge .....	23		
Air Bumping.....	23		
Power Failures and Loss of Air Supply .....	23		
Visual Inspection.....	24		
Air Main Inspection .....	24		
Operating Pressure and Airflow .....	24		
Aeration System Troubleshooting Guide .....	25		
<b>YEARLY MAINTENANCE AND DIFFUSER CLEANING</b>			
Maintenance Schedule.....	27		
Lubrication Schedule .....	27		
Ceramic Disc Diffuser Cleaning Method .....	27		
Membrane Disc Diffuser Cleaning Method .....	27		

# INTRODUCTION

This manual covers the Installation, Start-up, Plant Operation, Maintenance and Repair of the SANITAIRE Fine Bubble Aeration System.

This manual is used for both our Ceramic and Membrane Fine Bubble Disc Diffusers. The format and text of this manual have not been edited for specific projects and specification requirements.

We do realize that most projects have either Membrane or Ceramic Disc Diffusers and rarely have both; however, all of the components involved with these systems are interchangeable and are therefore combined in this manual.

Distinct sections are offered for the Plant Operation of the different Diffuser types. The operators should follow these accordingly.

Prior to beginning the installation process, the installing contractor should make sure the erection or "E" drawings are in their possession. The "E" drawings have the required part number designation and are essential for proper installation.



The Safety Alert Symbol means ATTENTION! BECOME ALERT! YOUR SAFETY IS INVOLVED!

## CAUTION

*This symbol and signal word indicate a potentially hazardous situation which, if not avoided, MAY result in minor or moderate injury. This symbol MAY also be used to alert against unsafe practices.*

## CAUTION

*This signal word indicates a situation which if not avoided, MAY result in product or property damage.*

The precautions listed in this manual are not all-inclusive. If a procedure, method, tool or part is not specifically recommended, you must satisfy yourself that it is safe for you and others, and that the system will not be damaged or made unsafe as a result of your decision.

This material may not be copied or reproduced in any way without prior written approval from Sanitaire.

# INSTALLATION AND START-UP

## RECEIVING AND SITE STORAGE

Prior to equipment arrival a dry, level temporary storage site should be made available.

Shipments made within the USA, Canada and Mexico will be delivered on flat bed trailer trucks. Unload components with a forklift or crane.

An export shipment will arrive in export containers. On these containers, the top and one end are removable.

Palletized and banded air distributor sections and/or palletized and wrapped boxes of equipment components are placed at the bottom of the container. Loose manifold sections, droplegs or boxes are placed on the top.

Remove the loose boxes by hand. Remove the loose manifold sections and droplegs by hand or with a crane and sling device.

Palletized boxes of equipment components will be placed near the open end for removal by forklift. The palletized air distributor sections are removed by using a crane and wire slings placed through the lifting lugs as shown in Figure 0.

**DO NOT** stack these shipping units.

**DO NOT** store the units where snow removal or other heavy equipment could cause damage.

**DO NOT** cover the pipe components with plastic. Excessive heat build-up can damage plastic pipe and will void the equipment warranty.

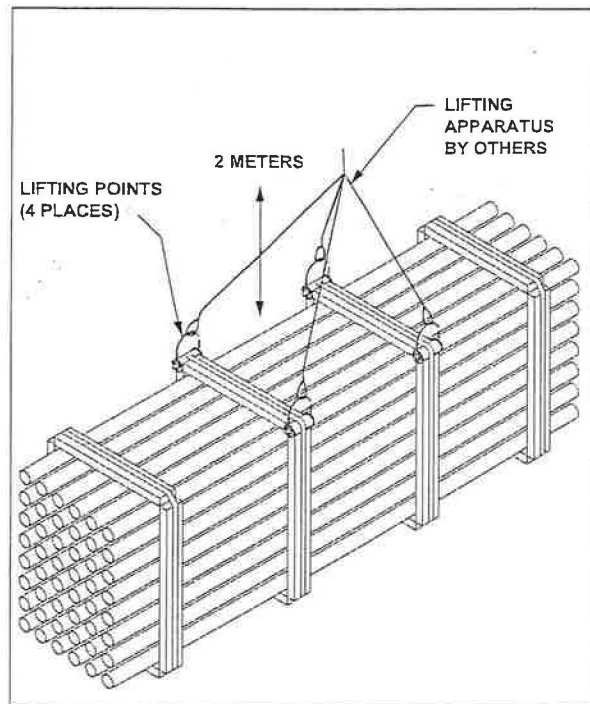

Figure 0

## PHYSICAL INVENTORY

Sanitaire has provided shipping lists for all components used for the aeration system in this manual. In addition, each shipment has a packing list of all items delivered.

Before installation, take a physical inventory of all components (by comparing the shipping and packing lists) and immediately report any missing or damaged items to Sanitaire.

# INSTALLATION AND START-UP

## DROPLEG AND MANIFOLD INSTALLATION

1. Attach the upper stainless steel portion of the dropleg to the air main.

### NOTE

When the upper dropleg is installed properly it should be vertical with its centerline located as shown on the erection drawings. (See Figure 1) The droplegs are shipped with protective end plugs which require removal prior to installation.

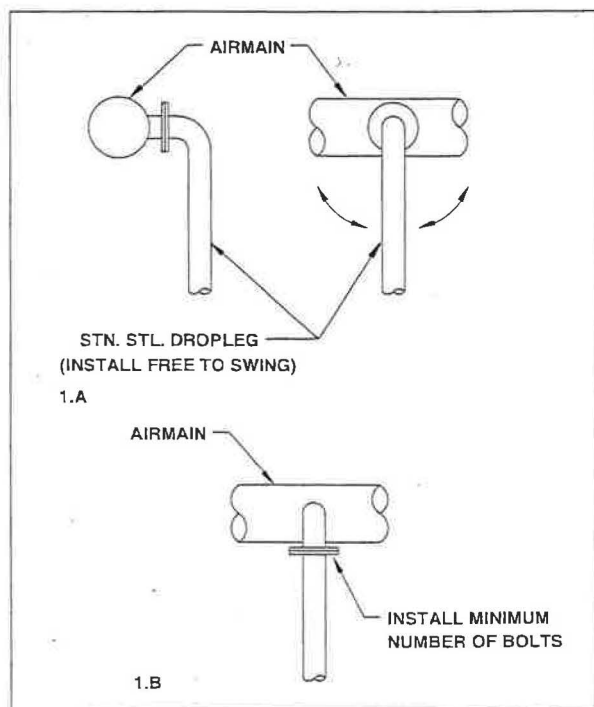

Figure 1

The air main must be capable of supporting the full weight of the upper stainless steel portion of the dropleg.

### CAUTION

Before installing the upper dropleg section, all dirt and debris must be removed from the air main. The air blowers are normally used for this operation. Air filtration equipment should be installed and operating prior to blowing out air lines. Blowers may require a minimum back pressure when operating. Be sure to follow manufacturer's requirements.

### NOTE

A) Droplegs with a top connecting elbow, as shown in Figure 1.A, should be bolted and tightened to the air main connection to a point which will allow the dropleg to be swung to the side when installing the lower PVC portion of the dropleg.

B) Droplegs with a horizontal flange connection, as shown in Figure 1.B, should be temporarily bolted tightly to the air main connection with a minimum number of bolts. The dropleg will have to be removed to install the lower PVC portion of the dropleg.

2. Use the installed stainless steel upper dropleg and the erection drawings to locate and layout the centerline of the aeration grid manifold.

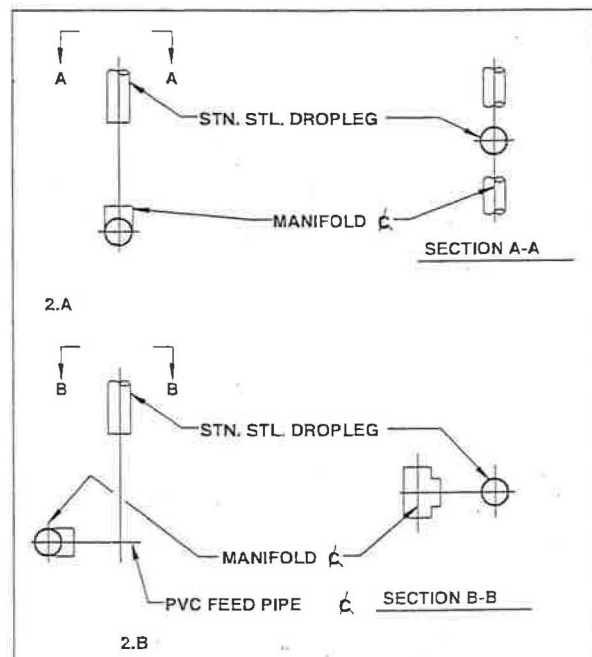

Figure 2

### NOTE

The dropleg connection on the manifold is a PVC socket tee or elbow. This connection can be located directly under the dropleg as shown in Figure 2.A or offset as shown in Figure 2.B. Review the erection drawings prior to manifold layout.

## INSTALLATION AND START-UP

3. Use the erection drawings and shipping lists to locate all manifold anchors and supports.

Six inch (150 mm) diameter or greater manifold supports are one of two types. Figure 3 shows a manifold support used for manifolds where the centerline elevation is less than 18" (457 mm) from the floor. Figure 4 shows a support which uses a stiffening strut on manifolds where the centerline is above 18" (457 mm) off the floor.

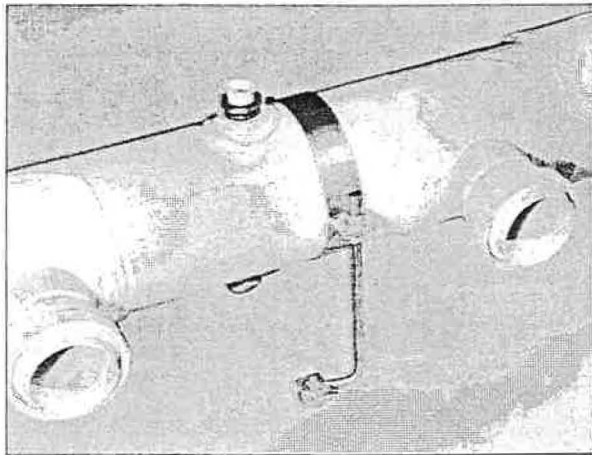

Figure 3

Manifolds which do not use the strut support are commonly referred to as in-line manifolds. Manifolds which have the strut support are referred to as raised manifolds.

Four inch (100 mm) diameter manifolds use a single anchor support as shown in Figure 23, these manifolds are in-line and do not require a support strut.

4. Use the erection drawings and manufacturer's installation instructions to layout and install the manifold anchors.

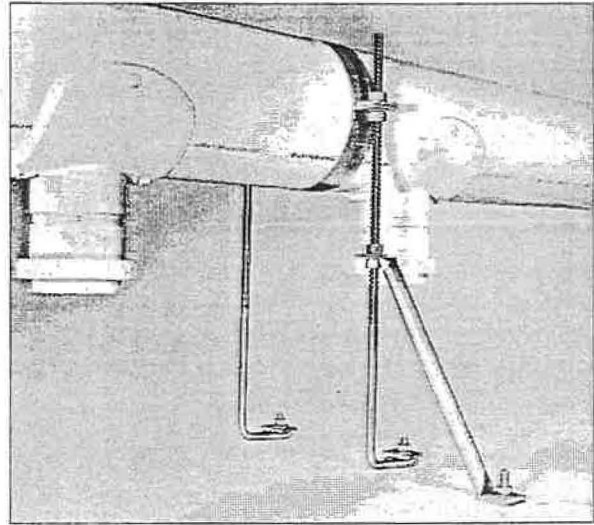

Figure 4

### NOTE

**A)** Before installing the anchors it is advisable to lay the manifold alongside the layout and double check for possible interference. This will require locating the correct manifold sections, lowering them into the tank, removing the dust covers off the ends and orienting the sections into the proper position. All manifold sections have a part number, shown on the erection drawings and marked on the pipe for easy identification.

If an interference does occur the manifold supports can be repositioned as long as the maximum support spacing is held to 8'-0" (2440 mm).

**B)** When installing anchors follow the tightening torque values as listed by the manufacturer in their installation instructions.

**C)** When installing anchors the threaded projection from floor level should be as shown on the erection drawing anchor table.



## INSTALLATION AND START-UP

- Install the manifold support base and struts if required. All floor mounted anchor nuts, washers and plate washers need to be installed. If 4" Ø (100 mm) manifolds are used, a locating plate must be installed as shown in Figure 25.
- Use a laser level system to bring the lower pipe clamp flange hex nuts to the proper elevation. The proper elevation will be the manifold centerline elevation as shown on the erection drawings (See Figure 6). Once the centerline elevation is set, install lower pipe clamps as shown in Figures 5, 7, and the erection drawings.

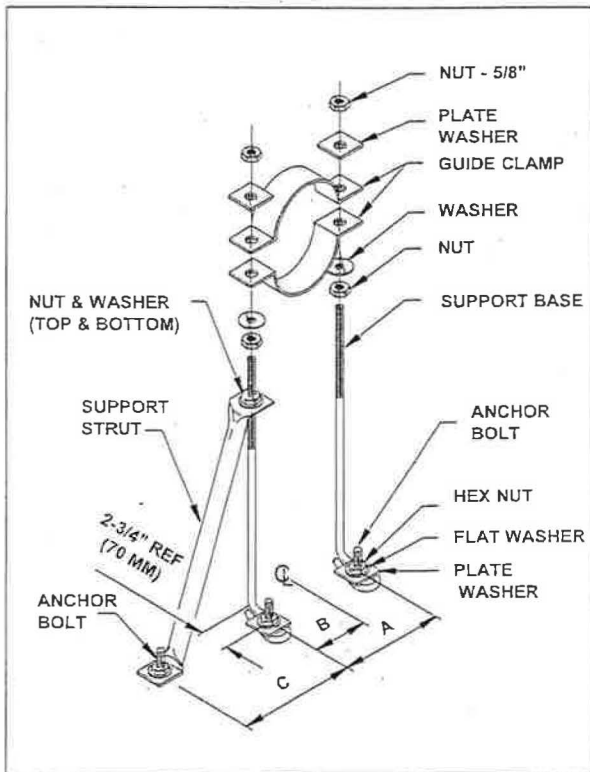

Figure 5

- Examine the manifold pipe sections. Remove all protective dust covers from the pipe ends and 4" Ø (100 mm) air distributor connections. Dispose of the dust covers and packaging material properly.

If pipe sections are dirty and contain debris from storage, flush with water prior to installation.

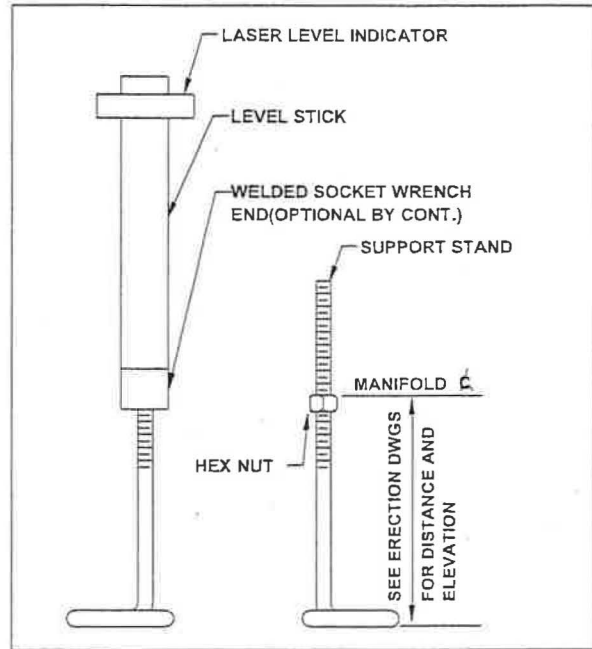

Figure 6

- Place the manifold sections in the lower clamp cradle of the supports. The correct orientation can be determined from the erection drawings.
- Make up any flange joints. Leave the bolts loose for now.

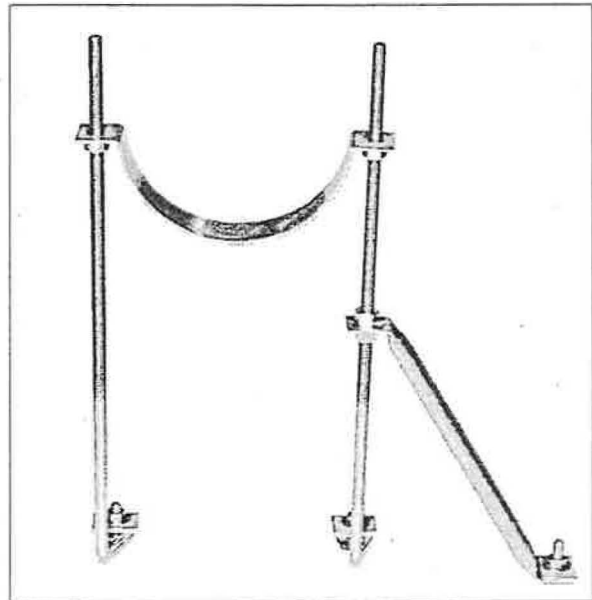

Figure 7

## INSTALLATION AND START-UP

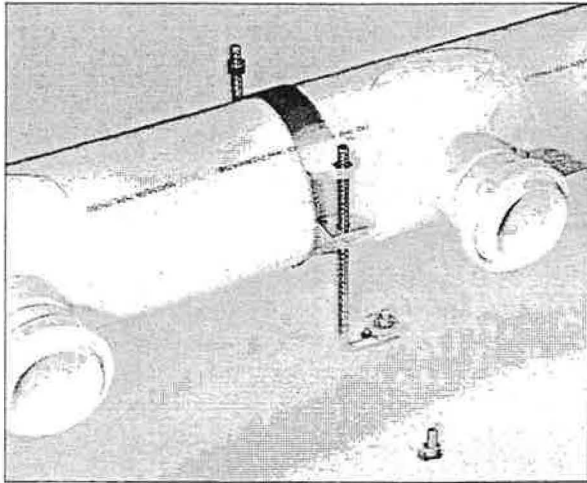

Figure 8

10. Install the upper half of the pipe clamp, plate washers and nuts. **Do not secure at this time.** See Figures 5, 8 and the erection drawings.
11. Level the manifold section which attaches to the dropleg so that the air distributor connections are plumb vertically for raised manifolds or level horizontally for in-line manifolds. See Figures 9 and 10.
12. Secure the pipe clamps on this section by tightening down the hex nuts on the top pipe clamp. Make sure the manifold pipe is level in a horizontal line parallel to the centerline.



Figure 9

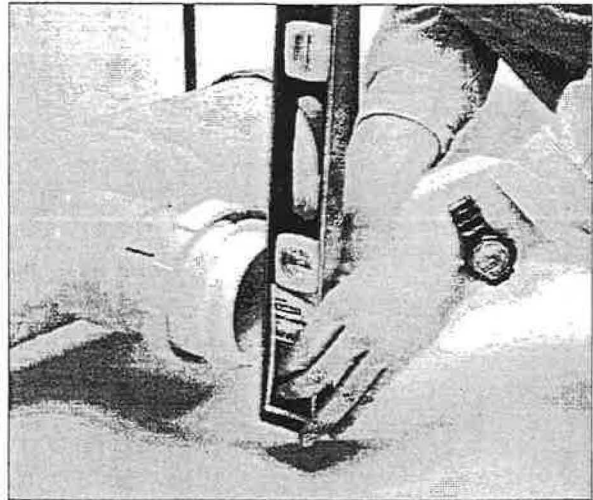

Figure 10

13. Using the following procedure, install the lower PVC portion of the dropleg:

**A)** With a heavy body solvent cement, field glue all required PVC feed pipe and fittings up to the last "cut to fit pipe section" which mates to the stainless steel upper dropleg section. See Figure 11 and the erection drawings. Install feed pipe supports as required and shown on the erection drawings.

### NOTE

*Manifolds where the upper stainless steel dropleg is positioned directly in-line with the manifold connection as shown in Figure 2.A, **DO NOT** require a feed pipe, fittings and supports.*

**B)** Measure the distance "X" from the end of the installed stainless steel upper dropleg to the insertion depth of the PVC socket fitting. See Figure 11.

**C)** Remove or swing the upper stainless steel portion of the dropleg out of the work area.

**D)** Cut or trim the lower PVC dropleg to the measured distance.

## INSTALLATION AND START-UP

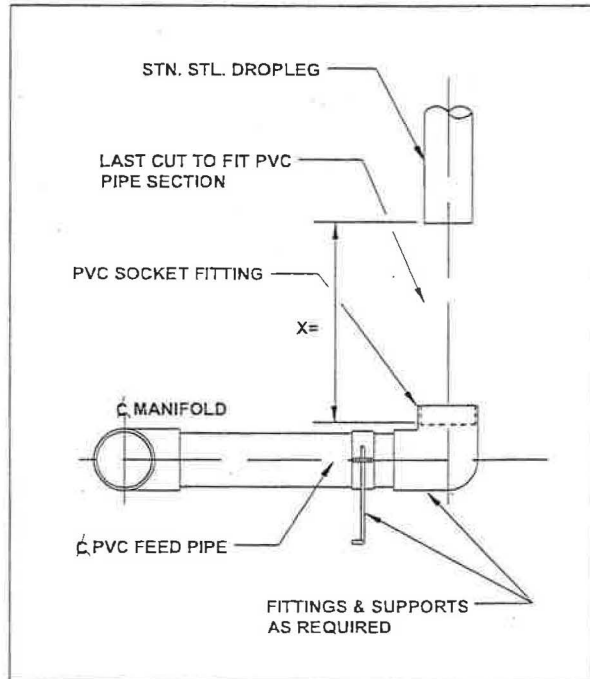

Figure 11

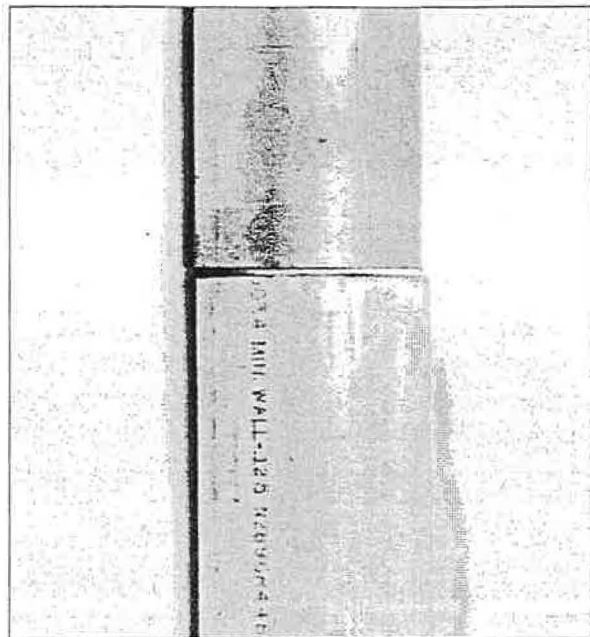

Figure 12

E) Solvent cement the lower PVC dropleg into the manifold connection fitting.

F) Reinstall and/or align the stainless steel portion of the dropleg. The gap between the stainless steel and PVC should be a maximum of 1/8" (3 mm). See Figure 12.

G) Install the clamp coupling or make the flange connection as shown in Figure 13 or 14. The clamp coupling bolts should be torqued to 50-55 ft•lbs (70-75 N•m).

### NOTE

Nearly all installations have the PVC and stainless steel pipe sections mating as plain ends (Figure 12) connected with a stainless steel clamp coupling (Figure 13); however, these two sections could mate with a flange connection as shown in Figure 14. If a flange connection is used, the flange overall and socket depths must be considered when cutting the PVC dropleg section.

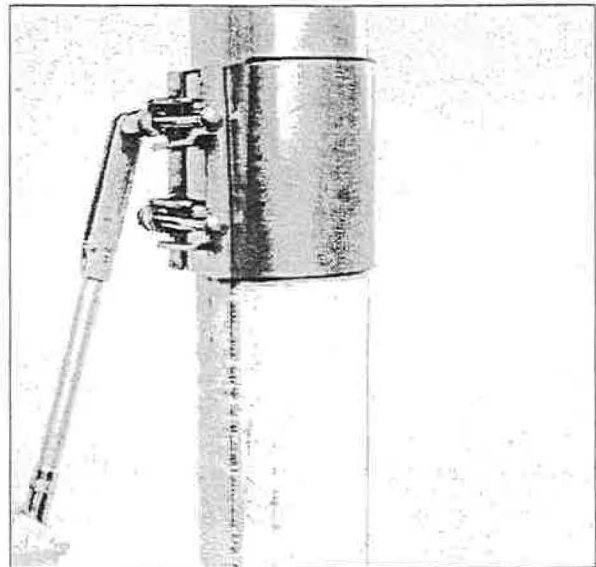

Figure 13

14. Once the complete dropleg is installed, refer back to steps 11 and 12 and secure subsequent manifold sections in the same manner. Align the air distributor saddle connections and tighten the flange joints. Level the manifold along its length and secure the pipe clamps.

## INSTALLATION AND START-UP



Figure 14

### AIR DISTRIBUTOR AND DRAINLINE INSTALLATION

This section covers the procedure for installing the air distributors and drainlines.

#### NOTE

*Separate drainlines are primarily used on fine bubble systems with raised manifolds. Nearly all systems with in-line manifolds will not have separate drainlines as the manifold serves as the drainline. See Figure 15 and the erection drawings.*

1. Using the erection drawings and the manifold air distributor connections as a guide, layout the centerline for each air distributor and drainline if applicable. See Figure 16, Step 1.
2. Mark the air distributor support locations on one of the outside layout lines. The spacing is shown on the erection drawings. See Figure 16, Step 2.
3. Assemble one complete air distributor section from the manifold to the end cap. Include the drainline pieces if applicable. Use the distributor sections as shown and marked on the erection drawings and the pipe itself. See Figure 17.

Remove the perforated plastic end covers prior to assembly. If the covers were previously removed or missing, check the inside of the pipe and flush out dirt and debris which may have accumulated during storage.

The air distributors are assembled using Sanitaire fixed or expansions joints.

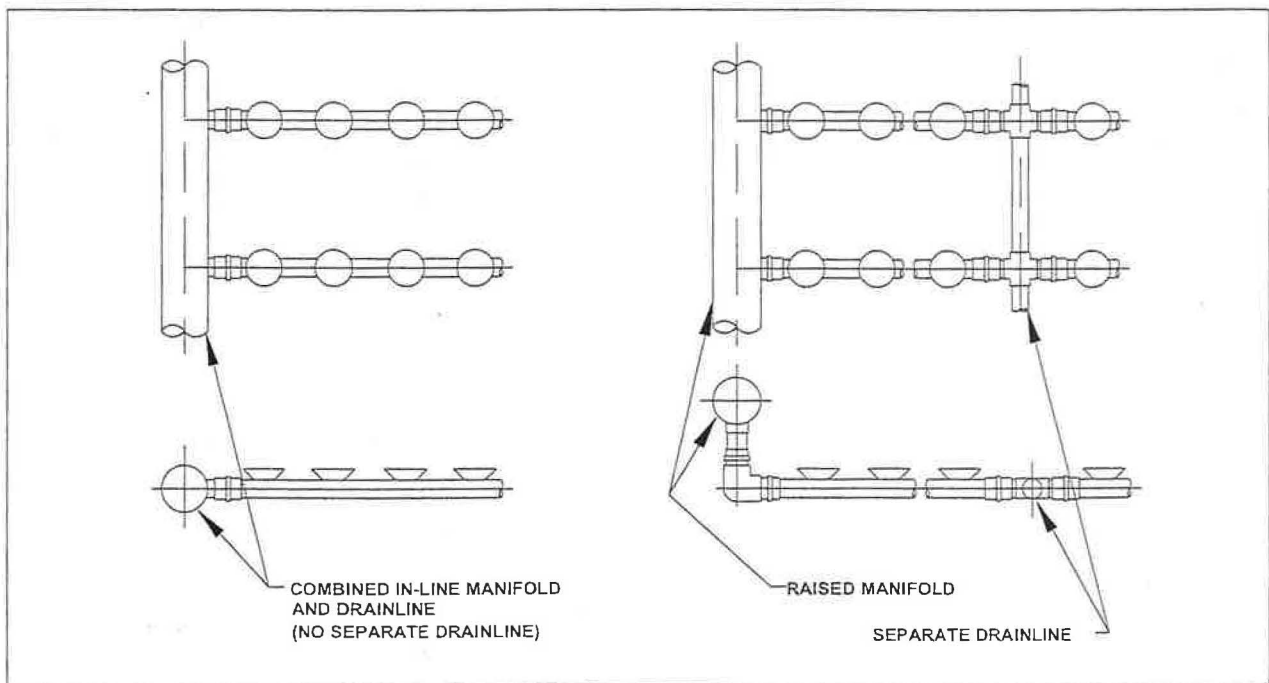

Figure 15

# INSTALLATION AND START-UP

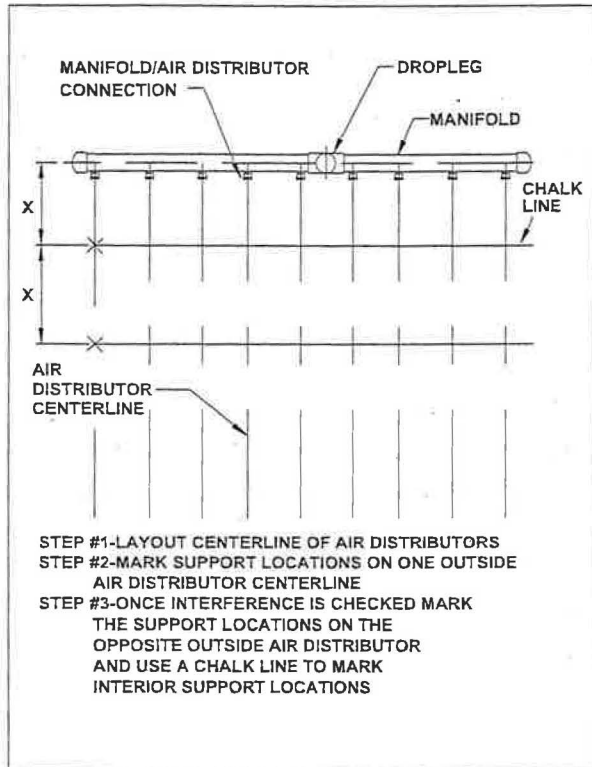

Figure 16

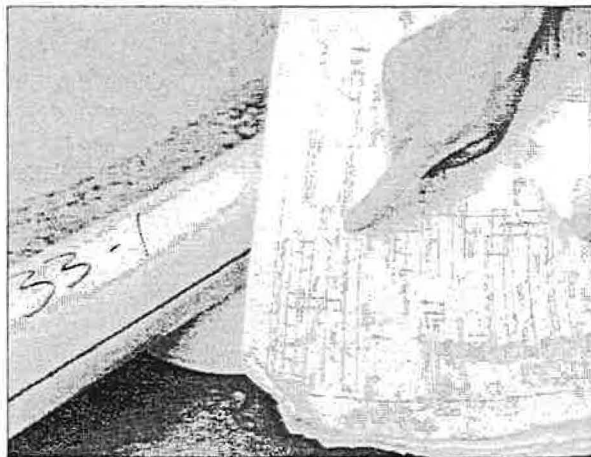

Figure 17

Assemble the fixed joint (ref. Figures 18 and 19) with a gray "O"-ring. This "O"-ring can be lubricated with a common dish soap solution for ease of installation. Place the "O"-ring on the spigot end of the fixed joint (see

Figure 19). Bring together the two sections of the pipe/joint and thread the retaining ring onto the socket end of the fixed joint to a hand tight position.

### NOTE

*The fixed joint is a spline joint. The spline design is used to prevent air distributor section rotation. To adjust the joint after the initial installation, the joint will have to be loosened and backed off until the splines are disengaged.*

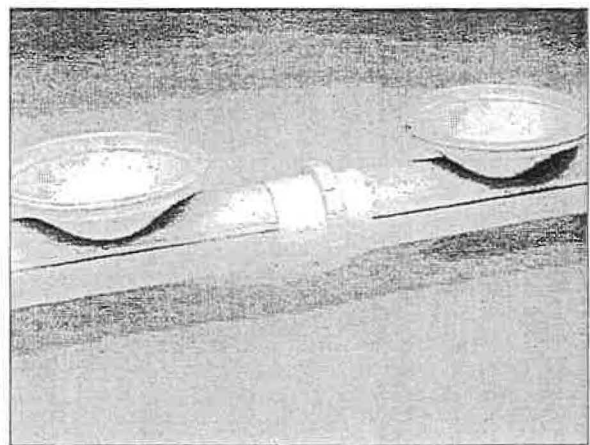

Figure 18

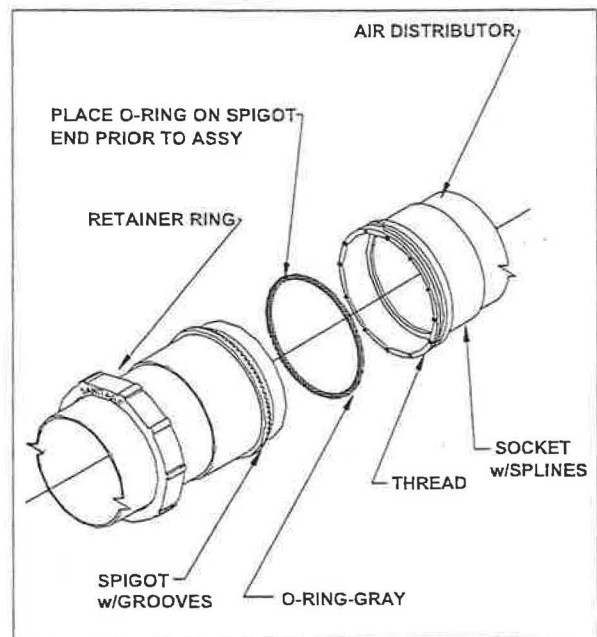

Figure 19

## INSTALLATION AND START-UP

Assemble the expansion joint (ref. Figures 20 and 21) with a black "O"-ring. This "O"-ring must be lubricated with a small amount of the silicone lubricant provided by Sanitaire prior to installation. Place a mark 2-3/8" (60 mm) from the end of the plain end distributor section. Place the "O"-ring over the mark and insert the plain end into the expansion joint barrel until the "O"-ring seats, then tighten the retaining ring to a hand-tight position.

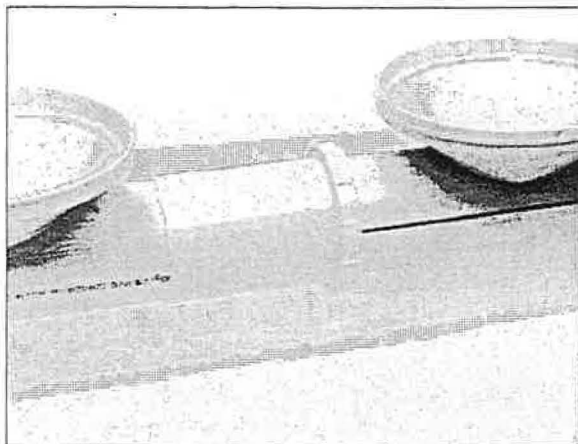

Figure 20

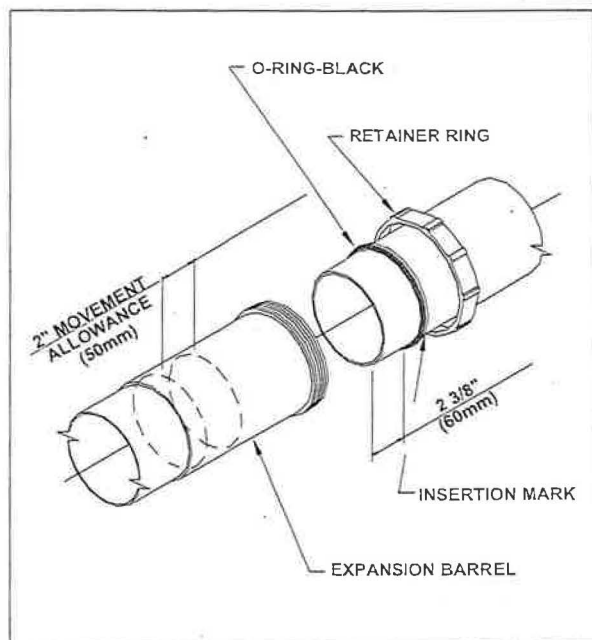

Figure 21

- Once the first air distributor section is assembled, lay it next to the anchor bolt layout previously done and check for interference between the diffuser holders, joints and supports (see Figure 22). Support locations can be adjusted as required as long as the maximum support spacing is held to 7'-6" (2286 mm).

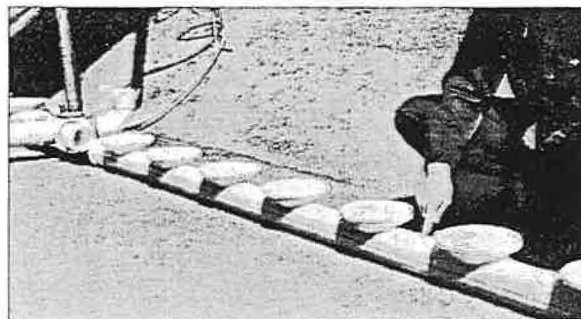

Figure 22

- Layout the locations of all air distributor support stands. See Figure 16, Step 3.
- Install the anchors and support base in accordance to the erection drawings and anchor manufacturer's installation instructions.

Sanitaire manufactures the following different types of air distributor supports.

**Rod Type Guide Support** — (see Figure 23). This is the most commonly used support. It has 5/16" Ø or 1/2" Ø rods, has a 5-3/4" (146 mm) center to center rod distance and uses light weight, oversized non-gripping pipe clamp.

The 5/16" Ø rods supports are used where the air distributor centerline does not exceed 12" (305 mm) from the floor and in areas where there are no external forces applied to the pipe sections by devices such as mixers.

The 1/2" Ø rod supports are used where the air distributor centerline exceeds 12" from the floor. This support is also used in areas where mixers may be operating.

Additional support struts maybe used on the 1/2" Ø rod supports depending on the air distributor elevation. If used, the proper location will be shown on the erection drawings.

## INSTALLATION AND START-UP

All 4" Ø (100 mm) manifolds will use 1/2" Ø supports regardless of location.

**Anchor Supports** — (see Figures 24, 26A and 26B.) Anchor supports are used after expansion joints. The anchor support has 1/2" Ø rods and a 5-1/4" (133 mm) center to center rod distance. The clamps are heavy gauge stainless and will clamp down tight on the pipe. Modifications to the anchor support will be used if the air distributor centerline exceeds 5" (127 mm) from the floor and may be the pedestal type as shown in Figure 26A or have stiffening struts applied as shown in Figure 26B.

**A-Frame Supports** — (see Figures 27A and 27B.) A-frame supports are a formed stainless structure that could be a fixed support as shown in Figure 27A or a guide type non-gripping support as shown in Figure 27B.

The A-frame can be used in areas of high turbulence, extreme floor slope or on end looped drainlines.

### General Notes on Air Distributor Support Installation

- A) Use the correct support at the proper location. See erection drawings.
- B) Sloped floors may require the use of several different support types and support rod diameters. See erection drawings.
- C) The rod type support base locating plate must be installed as shown per Figure 25. Tighten the hex nut to the recommended torque value as listed by the anchor bolt manufacturer in their installation instructions.

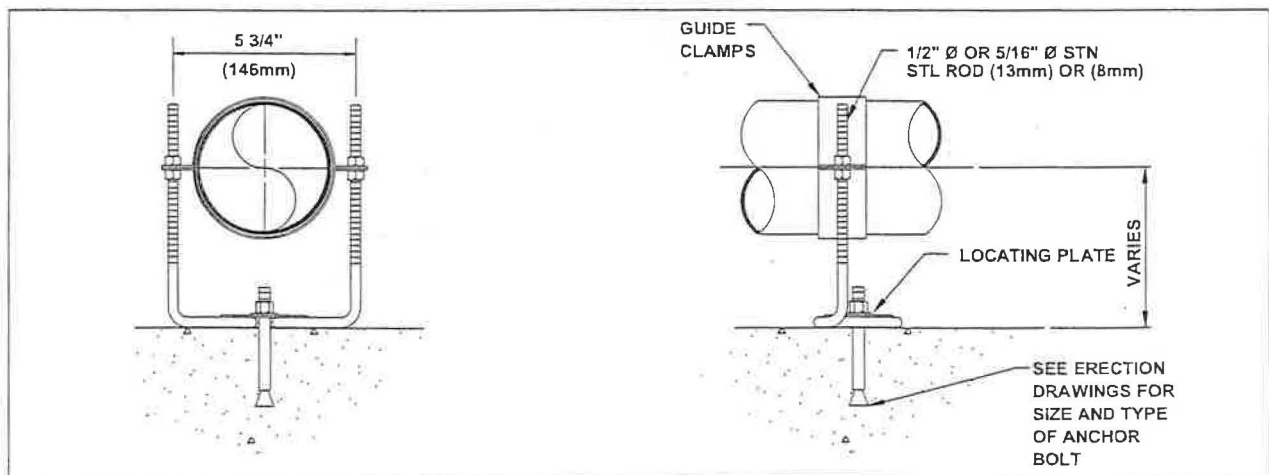

Figure 23

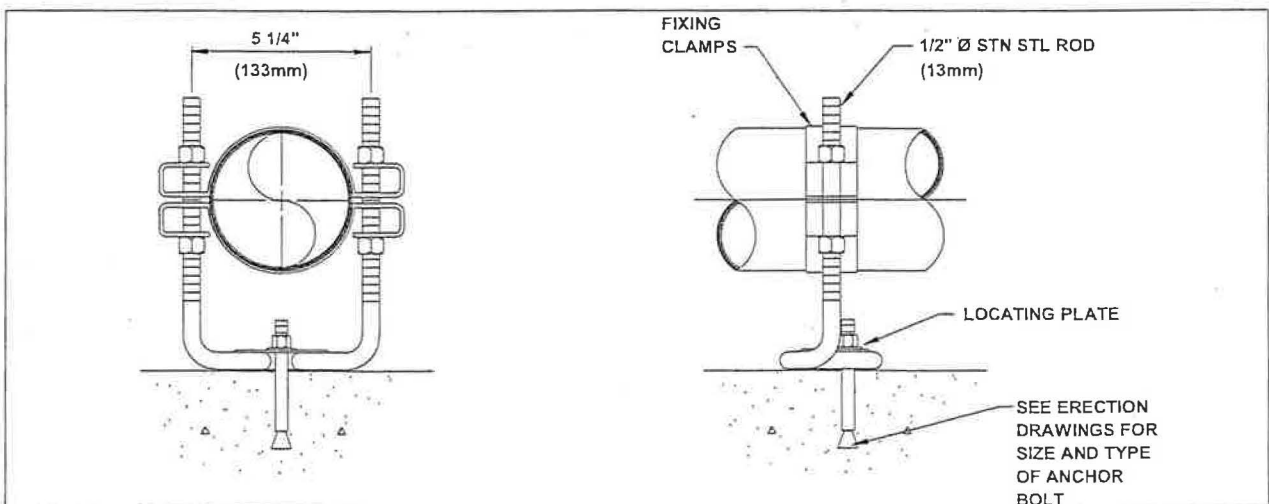

Figure 24

# INSTALLATION AND START-UP

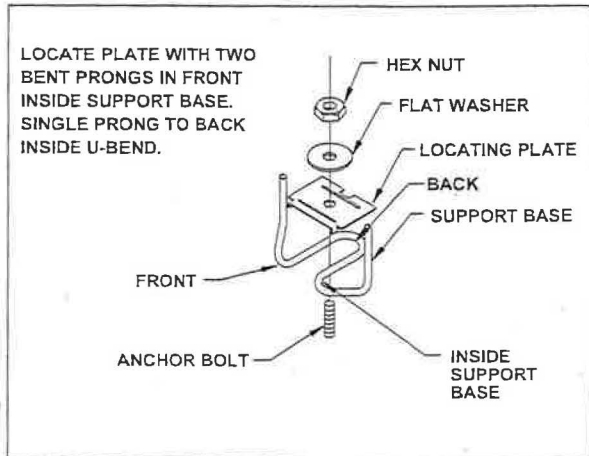

Figure 25

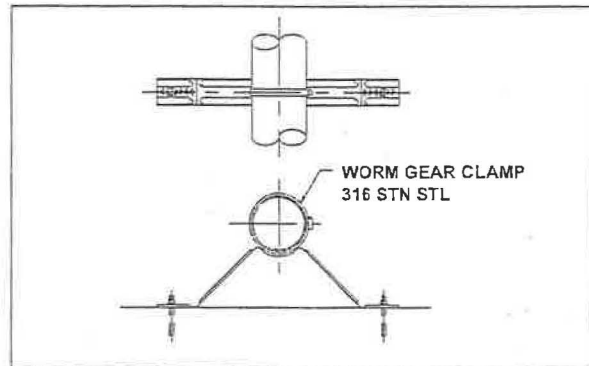

Figure 27A

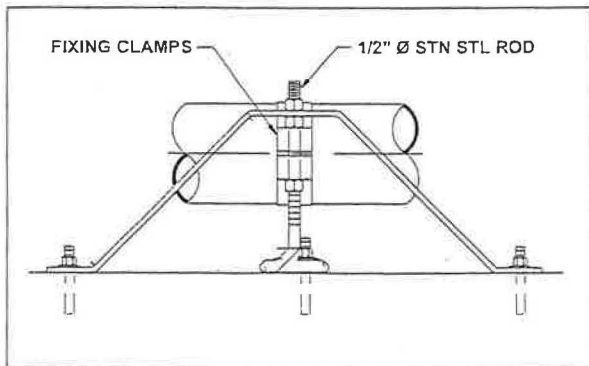

Figure 26B

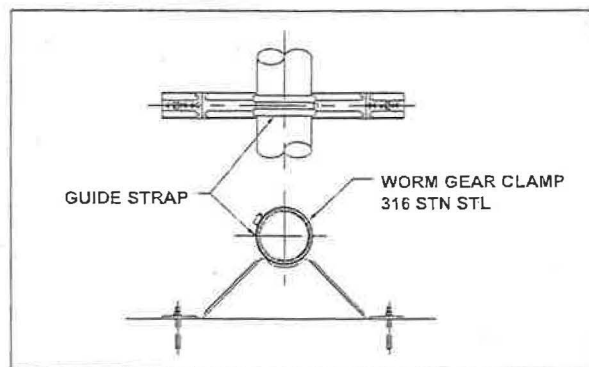

Figure 27B

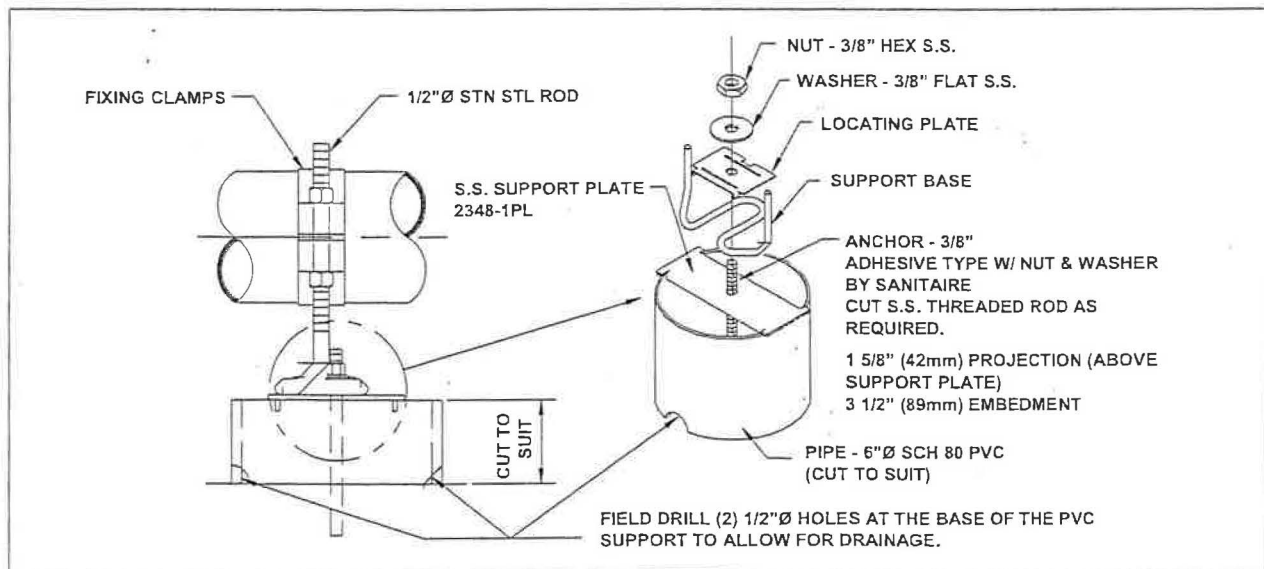

Figure 26A



## INSTALLATION AND START-UP

7. Install the lower pipe clamp sections on all air distributor and drainline supports.

Use the same technique as described in paragraph 6 of the dropleg and manifold installation section. The air distributor centerline elevation is shown in the erection drawings.

The air distributor centerline elevation tolerance is  $\pm 1/4"$  (6 mm).

8. Starting from the manifold, assemble the remaining air distributors in the support stands. Refer to step #3 of the air distributor and drainline installation section for joint assembly instructions.
9. Install the top half of the pipe clamp on each support and loosely install the top hex nuts.
10. Again, starting near the manifold, place a hand level on the top of diffuser holder perpendicular to the centerline of the distributor pipe. See Figure 28.

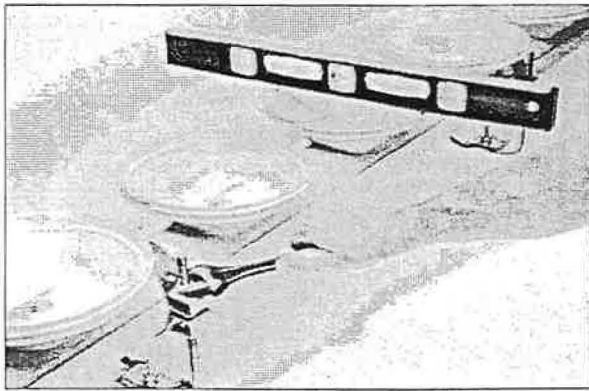

Figure 28

11. Rotate the distributor section until the pod is level.
12. Hold the pipe section level and tighten all fixed joints and/or anchor support clamps on sections which have an expansion joint.

13. After tightening, recheck for level both perpendicular and parallel to the distributor section.
14. Continue this procedure for all distributor and drainline sections.
15. Tighten all guide support nuts.

### CAUTION

*The guide support will be loose around the pipe – this is a design feature. Do not attempt to wrap anything around the pipe to pull the clamps tight against the pipe. See Figure 29.*

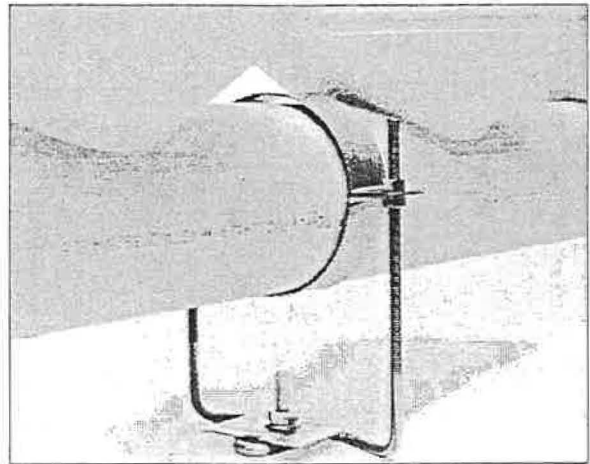

Figure 29

### PURGE SYSTEM INSTALLATION

Sanitaire provides two types of purge system.

The most commonly used purge system consists of a sump and evacuation pipe.

- The sump for systems using in-line manifolds is built into the manifold pipe as shown in Figure 30A.

## INSTALLATION AND START-UP

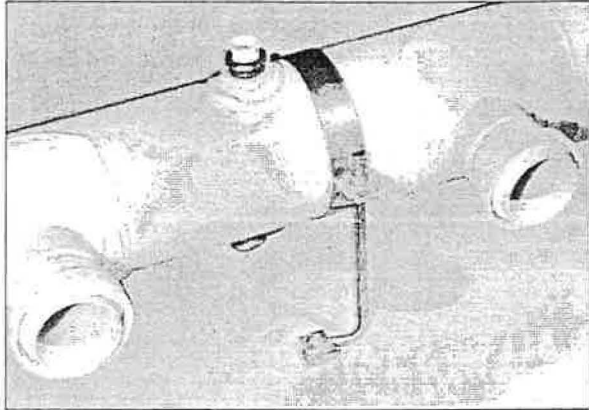

Figure 30A

- The sumps for systems using the raised manifold is attached to an air distributor or drainline section as shown in Figure 30B.

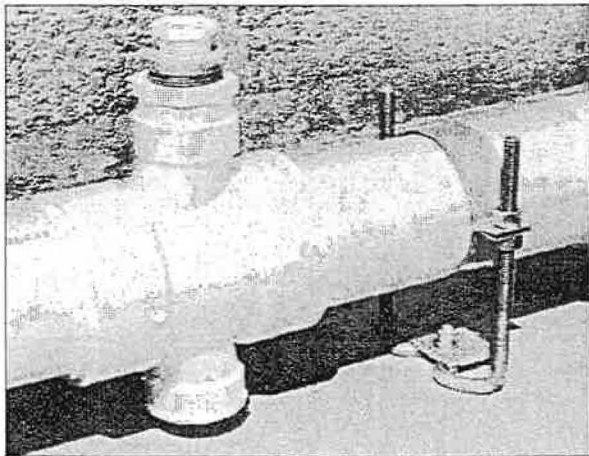

Figure 30B

- The evacuation pipe consists of 3/4" Ø (20 mm) Schedule 80 PVC pipe, fittings, and a valve mounted to the tank wall. See erection drawings for installation details.

The second type of purge system is the continuous purge system as shown in Figure 31. The manifold or an air distributor section is tapped at a low point and a membrane tube is attached. The membrane tube is placed at an elevation lower than the manifold or air distributor section.

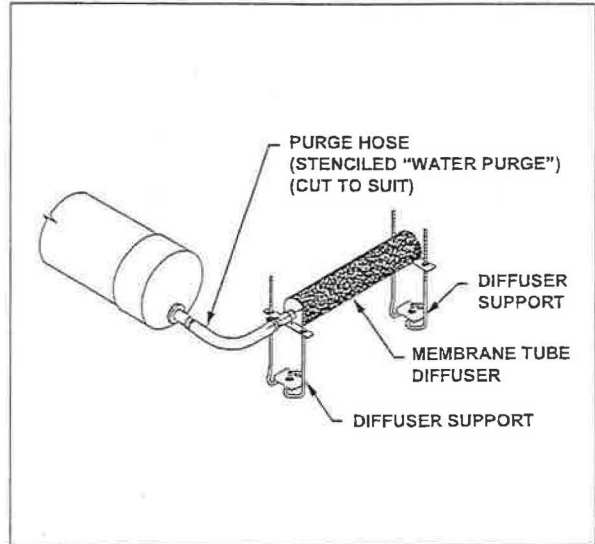

Figure 31

### DIFFUSER INSTALLATION

Sanitaire manufacturers two (2) types of fine bubble disc diffusers. These are the Ceramic Disc or the Rubber Membrane Disc.

Some general installation guidelines, are as follows:

1. Install the diffusers just prior to the scheduled start-up of the aeration basin.
2. The diffuser holder must be cleaned prior to diffuser installation. See Figure 32.
3. Check the erection drawings for the location of possible blank diffuser sites and plug the orifice hole in accordance with Figure 37 and the installation instructions found on page 15.



Figure 32

# INSTALLATION AND START-UP

## To Install CERAMIC DISC diffusers:

1. Set the diffuser disc in the holder with the dished side and peripheral stepped edge up.
2. Lubricate the diffuser "O"-ring with a small amount of the lubricant provided by Sanitaire.
3. Place the diffuser "O"-ring in the slot or void between the diffuser holder vertical wall and the raised portion of the diffuser disc. See Figure 33.

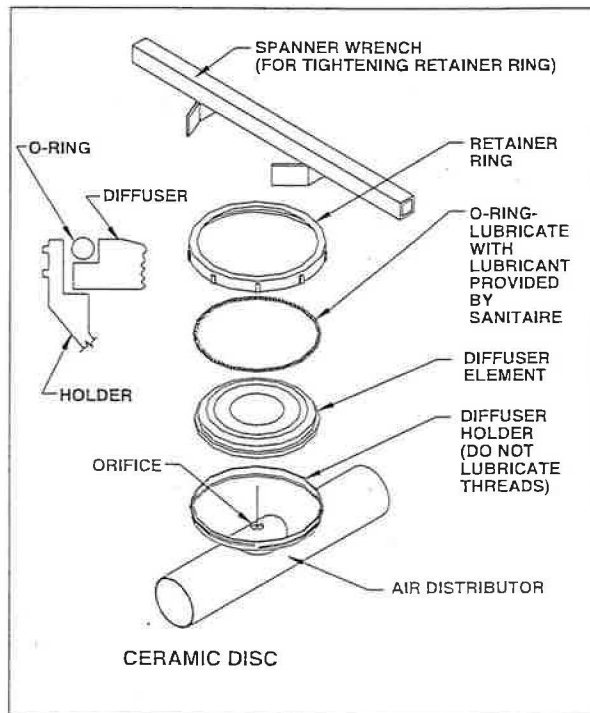

Figure 33

4. Turn the retaining ring to a hand-tight position making sure the "O"-ring stays in place.
5. Using the retaining ring spanner wrench, turn the retaining ring an additional 1/4 turn. See Figure 34.

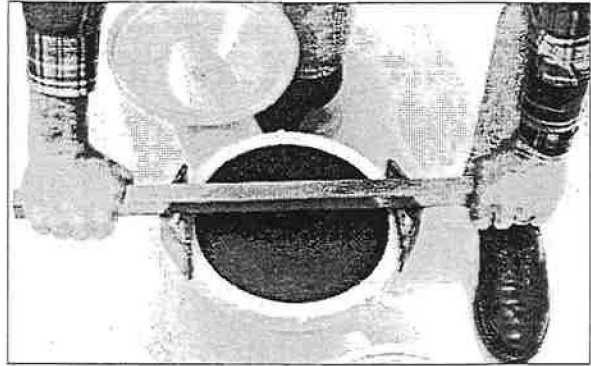

Figure 34

## To Install MEMBRANE DISC diffusers:

1. Set the diffuser PVC subplate in the diffuser holder with the flat side up. See Figure 35.

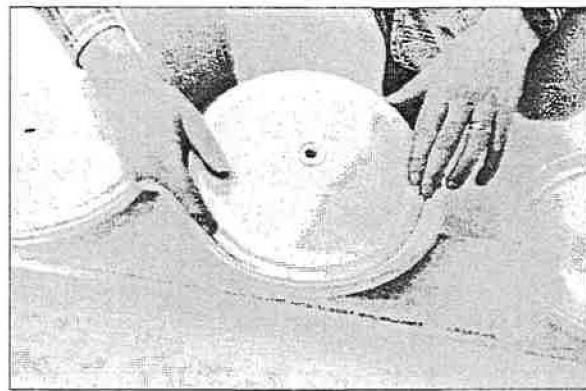

Figure 35

2. Place the membrane disc over the subplate. The integral "O"-ring should naturally fit down into the void created between the diffuser holder vertical wall and subplate.
3. Lubricate the diffuser retaining ring with a small amount of lubricant provided by Sanitaire by turning the ring upside down and swabbing the lubricant on the underside of the top surface of the retaining ring. See Figure 36.

## INSTALLATION AND START-UP

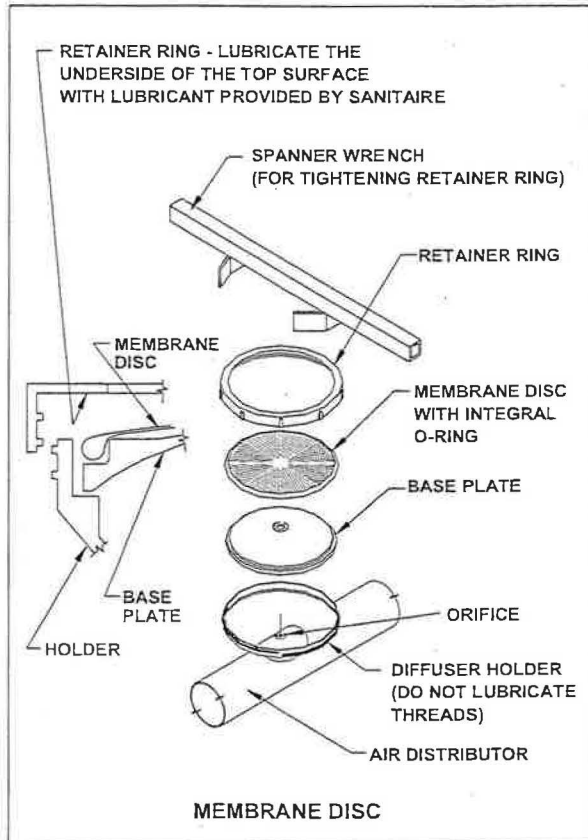

Figure 36

4. Turn the retaining ring to a hand-tight position.
5. Using the retaining ring spanner wrench, turn the retaining ring an additional 1/4 turn. See Figure 34.

### BLANK DIFFUSER SITE ORIFICE PLUG INSTALLATION

Some projects will call for some of the diffusers to be initially not put into operation or left "BLANK". These diffusers may be put into operation as process demand dictates.

Locate "BLANK" diffuser sites and plug the orifice as shown in Figure 37 and described on the erection drawings.

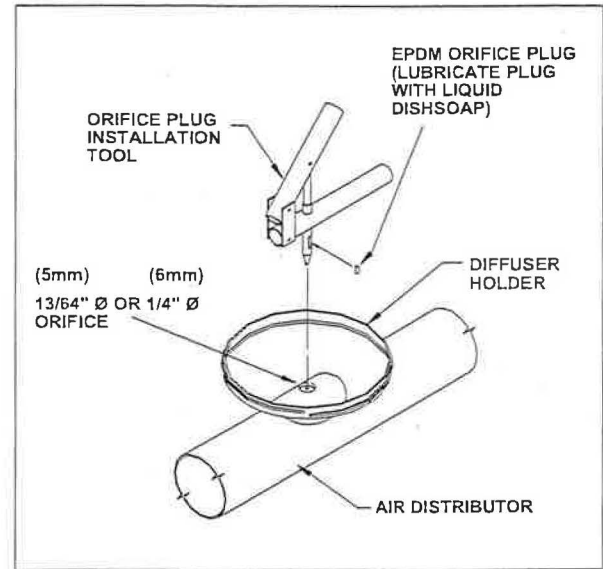

Figure 37

### AERATION SYSTEM START-UP PROCEDURE

Once the aeration system is installed, perform a final tank inspection and look for loose nuts, missing or improperly placed hardware, missing retaining rings, non-connected joints, etc.; and make any repairs prior to following this start-up procedure.

#### NOTE

*The start-up procedure should be completed prior to the site visit by Sanitaire service personnel or an authorized representative. This practice will save time for all parties involved.*

The start-up procedure is as follows:

1. Fill the aeration tank with clean water to a level 1" (25 mm) below the top of the diffusers. While filling, proceed with steps 2-5. Step 6 will require a visual level inspection with the water level 1" (25 mm) below the top of the diffuser.

#### CAUTION

*Water should be introduced to the basin at a rate and direction so that no abnormal stresses are imposed on the aeration pipe network that could cause damage.*

## INSTALLATION AND START-UP

2. While filling, disconnect each of the purge hoses from the sumps (not required on continuous purge systems).
3. When the water level reaches a point just over the top of the air distributor pipe, turn the air on at a low air flow rate of approximately 0.5 scfm/diffuser (0.85 m<sup>3</sup>/hr/diffuser).
4. Check all submerged fixed, flanged, or expansion joints for air bubbles, which indicate leaks, and repair as required.

### NOTE

*Leaking at fixed and expansion joints is generally due to one of three conditions:*

- "O"-ring pinched or out of place (most common).
- Joint retaining ring cross threaded on spigot.
- Joint not tight.

### ⚠ CAUTION

*When repairing pipe joints, turn off the air supply to the grid being worked on.*

5. With the air ON, check each purge sump operation. Any water trapped in the pipe should be discharging from the sump assembly.

If neither air or water is being discharged, check the sump eductor tube air orifice hole (see Figure 38). This hole may be plugged with debris or possibly glued over during manufacturing. Redrill or clean out as required and reassemble.

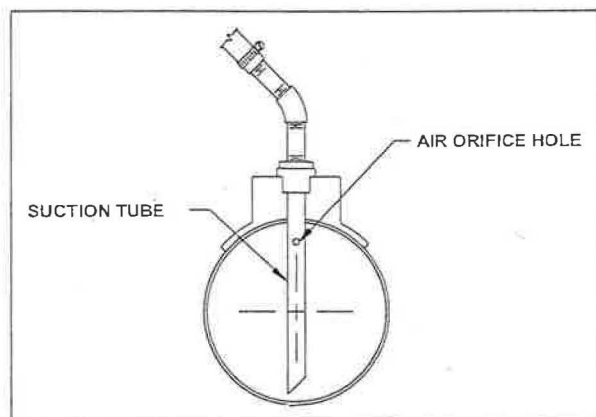

Figure 38

6. Turn the water supply OFF as it approaches a level 1" (25 mm) below the top of the diffusers. With the water OFF check the level of the aeration system. The distance from the top of the perimeter of the diffuser measured to the static water level should be relatively constant  $\pm 1/4$ " (6 mm) for all diffuser heads. Raise, lower, or rotate the air distributor sections as required in order to level the aeration system.
7. Increase the air rate to about 1-1.5 scfm/diffuser (1.7 - 2.6 m<sup>3</sup>/hr/diffuser) and turn the water supply back on.
8. Fill the basin to a maximum water level of 2" - 3" (50-75 mm) over the diffusers.
9. Check all diffuser units for uniform air distribution. Air should be discharging uniformly across the diffuser surface. See Figure 39.



Figure 39

Excessive air discharge as indicated by large coarse bubbles around the perimeter or "halo" of the diffuser indicates a loose retaining ring or improperly seated "O"-ring (see Figure 40). To correct this situation use the retaining ring spanner wrench to back off the retaining ring. Then reseal the "O"-ring and retighten to a hand-tight plus 1/4 turn position.

If no air is discharging from the diffuser surface, the air control orifice may be plugged with debris. To correct this situation, remove the diffuser assembly, clear the orifice (a welding rod or nail works well), and reinstall the diffuser.



## INSTALLATION AND START-UP



Figure 40

10. Once the system is leak free and is purged of all entrapped water, reattach the purge hoses to the purge sumps.
11. Use a soap solution to check for leaks at the clamp coupling or flange joint which joins the PVC and stainless steel portions of the drop-leg.
12. Continue filling the basin to a point 3'-4' (1 m) over the diffusers.

### NOTE

*If your system has a raised manifold (ref. Figure 4), check for manifold flanged or fixed joint connection leaks as the water level rises and repair as required.*

13. Allow the system to operate 3-4 hours in this mode prior to introducing the mixed liquor.

# PLANT OPERATION

## PRINCIPLES

The removal of carbonaceous BOD, the coagulation of non-settable colloidal solids, and the stabilization of organic matter are accomplished biologically using a variety of microorganisms (principally bacteria) in the activated sludge process. The microorganisms convert the colloidal and dissolved carbonaceous organic matter into various gases and cell tissue through synthesis.

Aerobic systems require the presence of molecular oxygen to maximize the conversion of the organic matter through a complex series of Biochemical Oxidation and Reduction Reactions.

Oxygen needed by the microorganisms is transferred to the mixed liquor by aeration. The fine bubble aeration system takes compressed atmospheric air and passes it through the diffuser element forming millions of fine bubbles that pass through the mixed liquor. Diffusion makes the oxygen in the compressed air accessible to the microorganisms.

Typically, fine bubble aeration systems are twice as efficient as coarse bubble systems. This translates to a 50% reduction in the required air volume to treat the same waste. Fine bubble systems are more efficient due to the increase in contact surface area between the air bubble and wastewater which makes the diffusion of the oxygen quicker/unit volume.

The drawback to the increased efficiency is that overtime fine bubble aeration systems may foul and require cleaning.

## DIFFUSER OPERATING AIR FLOW RANGE

For CERAMIC DISC (air flow per diffuser):

SIZE	MIN	MAX
9" (230 mm)	0.5 scfm. (0.85 m <sup>3</sup> /hr)	3.0 scfm (5.0 m <sup>3</sup> /hr)
7" (178 mm)	0.35 scfm (0.6 m <sup>3</sup> /hr)	2.0 scfm (3.5 m <sup>3</sup> /hr)

### NOTE

*Above listed air flow rates are general design standards. Actual project design may vary.*

## Ceramic disc operating requirements:

1. Do not operate below the minimum air flow requirements. Solids settling will occur which results in a loss in oxygen transfer efficiency and possible diffuser fouling.
2. Non-operating ceramic discs allow mixed liquor to enter the pipe network. Do not intentionally shut off the air flow to the ceramic discs in a submerged state.

## For MEMBRANE DISC (air flow per diffuser):

SIZE	MIN	MAX
9" (230 mm)	0.5 scfm (0.85 m <sup>3</sup> /hr)	Short term: 7 scfm (11.9 m <sup>3</sup> /hr) Long term: 4 scfm (6.8 m <sup>3</sup> /hr)
7" (178 mm)	0.35 scfm (0.6 m <sup>3</sup> /hr)	Short term: 4.8 scfm (8.1 m <sup>3</sup> /hr) Long term: 3.0 scfm (5.0 m <sup>3</sup> /hr)

### NOTE

*Above listed air flow rates are general design standards. Actual project design may vary.*

## PLANT OPERATION

---

### Membrane disc operating requirements:

1. When operating, do not reduce the air flow rate below the recommended minimums. Solids settling will occur which results in a loss of oxygen transfer efficiency and possible diffuser fouling.
2. Membrane disc systems are designed for continuous or intermittent submerged process use. Idle systems should be supplied with an alternate source of mixing.

#### NOTE

*Solids will settle on the diffuser surface of idle systems and may promote diffuser fouling. The results of intermittent use are as follows:*

- *A higher airflow and pressure may be required to lift the membrane disc off the subplate and start the grid.*
- *The diffuser may have to be cleaned if a sufficient loss in Oxygen Transfer efficiency is observed.*

### General notes regarding air flow range

- The most common design average air flow range is 1 to 2 scfm/Diffuser (1.7 to 3.5 m<sup>3</sup>/hr/Diffuser).
- Operating above this range results in a lower oxygen transfer efficiency and increased diffuser headloss.
- It may be necessary to operate at a higher air-flow rate in order to meet the oxygen demand.
- Operating below this range will yield a slightly higher oxygen transfer efficiency, however, mixing requirements must be considered.

### MIXING, D.O. LEVELS AND MINIMUM DIFFUSER AIR FLOW RATES

The generally accepted activated sludge plant mixing air rate standard is 0.12 scfm/Ft.<sup>2</sup> (2.2 m<sup>3</sup>/hr/m<sup>2</sup>) of tank surface area.

Often times conservative design will specify more diffusers with a higher minimum air flow requirement than is required by the process demand or

mixing in a specific area. This is most common at the end of long plug flow reactors. The result of this is a high area D.O. level.

If the operator feels this D.O. level is not needed, the simplest solution is to take some of the diffuser units out of service by plugging the orifice as shown in the installation instructions. See Figure 37.

#### NOTE

*Minimum mixing requirements must still be adhered to.*

### DIFFUSER FOULING

Operating experience shows that all fine bubble disc diffusers may foul or become clogged with continuous operation.

The rate of fouling, type of foulant, and strength of foulant depends primarily on the constituents in the wastewater.

The results of diffuser fouling include:

- loss of oxygen transfer efficiency due to bubble coalescence and coarse bubbling
- increased pressure requirements
- increased air demand.
- increased operating costs.

Diffuser fouling is divided into two categories: water side and air side. Air side fouling is very rare but does warrant some consideration. Water or mixed liquor side fouling is most common.

Causes of diffuser fouling include:

#### on WATER side:

- Fibrous material adhering to the edges of the diffuser units.
- Oils and greases in the wastewater.
- Precipitated deposits of iron and carbonates.
- Biological growths of slime.



### on AIR side:

- Dust and dirt from unfiltered or inadequately filtered air.
- Rust and scale from air main corrosion.
- Oxidation and subsequent flaking of bituminous air main coatings.
- Construction debris
- Mixed liquor solids entering through system leaks or cracks.

Several ways of determining if the diffusers are fouled are discussed in the preventative maintenance section of this manual.

The corrective action for fouled diffusers is cleaning. This is discussed in the yearly maintenance and diffuser cleaning section of this manual.

# PREVENTATIVE MAINTENANCE

## MOISTURE PURGE

Moisture enters the pipe system in three ways:

- Condensate build-up inside the pipe system due to high blower discharge temperatures and moist or humid air (primary cause).
- Minor leaks in the pipe system.
- Back flow through ceramic diffusers caused by a loss of air.

### NOTE

*Membrane diffusers are designed to seal on the subplate and prevent moisture from entering the system.*

The effects of entrapped moisture are:

- Increased air velocity and headloss.
- Poor air distribution.

Sanitaire manufactures two types of purge systems: a standard, manually operated system (most common) and a continuous purge system.

The standard system uses a sump with an educator line that extends from the grid to above the water surface and ends with a manual ball valve. To operate this system simply open the ball valve and the trapped liquid will be purged from the system. Close the valve when the water flow stops and a mist appears.

### NOTE

*For maximum purge results, lower the air flow to the grid. The air velocity will be reduced and more of the liquid will be forced to the sump.*

The purge frequency is site determined; however, once a week is a good rule of thumb.

The second type of purge system is the continuous purge system which employs a diffuser unit attached to the bottom of the manifold or drain-line. The entrapped moisture is continuously purged from the system.

The continuous purge systems are used on grids where it is not possible to reach a purge valve safely from a walkway.

## AIR BUMPING

Air bumping is a technique that can be employed by operators to temporarily reduce back pressure in the system. Air bumping is the act of increasing the air flow rate per diffuser for 20-30 minutes once per week. An air rate per diffuser of 3 Scfm (5 m<sup>3</sup>/hr) is generally used.

This practice will aid in sloughing off settled debris and may extend the period between diffuser cleanings.

## POWER FAILURES AND LOSS OF AIR SUPPLY

The results of a power failure (loss of air supply) on each diffuser type are as follows:

### for CERAMIC DISC diffusers:

- Solids settle on diffuser surface.
- Filtered mixed liquor penetrates the diffuser and enters the pipe network.
- Short term affect: none.
- Long term affect: fouling may occur on the surface and within the diffuser disc.

When the air supply is restored, the air pressure will build and the flow will reduce until sufficient water is pushed out of the system to allow air to be released through the diffusers.

## PREVENTATIVE MAINTENANCE

---

### NOTE

*It is suggested that the operator open the purge valves as soon as possible after a power outage and evacuate the system. If the liquid is left in the system the flow will be reduced and the operating pressure will be higher than normal.*

### for MEMBRANE DISC diffusers:

- Solids settle on diffuser surface.
- Short term affect: none.
- Long term affect: the potential of surface fouling is possible and the diffusers may require a cleaning. This is generally the case for long term intermittently used membrane disc systems (i.e., Anoxic Zones; Batch Reactors).
- May require operator to shut off adjacent grids or turn on additional blowers to increase the air flow rate and force the membrane off the subplate surface. This is again generally the case for long term intermittently used membrane disc aeration systems.

### VISUAL INSPECTION

Visually inspect the aeration basin surface pattern. The flow should be, for the most part, a nice

quiescent pattern. Some coarse bubbling at the basin inlet may occur due to surfactants in the wastewater and is generally dispersed shortly downstream.

Excessive coarse bubbling throughout the tank indicates the diffusers may be fouling.

Large boiling in an isolated area indicates a failure in the submerged pipe system.

Visual inspection is an ongoing preventative maintenance step and can be done while taking routine samples, dissolved oxygen readings, etc.

### AIR MAIN INSPECTION

Air main leaks are easily identified and usually are caused by loose joints or degraded gaskets. These types of leaks should be repaired quickly in order to prevent loss of system efficiency.

### OPERATING PRESSURE AND AIRFLOW

Most blower systems are equipped with discharge pressure gauges. The operator should keep a regular log of pressure readings. A continuous increase in operating pressure indicates diffuser fouling. Likewise, a continuous increase in air demand without a change in the aeration basin loading indicates diffuser fouling.

## PREVENTATIVE MAINTENANCE

### Fine Bubble Grid Aeration System TROUBLESHOOTING GUIDE

Problem	Cause	Action
<b>VISUAL INSPECTION</b>		
Poor air distribution	Diffusers not level	Level system
	Grid flooded	Operate grid purge system
	Plugged orifice	Clean orifice
	Insufficient air	Provide more air
	Solids settling	Provide more air to grid
Visible mounding of air in one location	Broken pipe	Repair (see repair procedures)
Coarse bubbling (large bubbles)	Diffuser fouling	Clean diffusers (see cleaning procedure)
Air discharge from air main	Loose joints, degraded gaskets, or degraded air main	Repair as required
<b>OPERATIONAL PROBLEMS</b>		
Low D.O. Concentration	Too little air	Increase air flow
High D.O. Concentration	Too much air	Decrease air flow
		Decrease quantity of diffusers in service
Increased operating pressure	Diffuser fouling	Clean diffusers (see cleaning procedure)
	Line blockage or valve closed	Check air lines and valves
Increased air requirement/ no load change	Diffuser fouling	Clean diffusers (see cleaning procedure)
	Leak in air system	Inspect and repair as required

## **WARNING:**

Prior to draining a tank, please **READ** these instructions carefully to minimize the potential for heat related damage to the Aeration System.

---

### **BASIN DRAINING PROCEDURE**

Before draining a basin for diffuser inspection, tank cleaning or other maintenance operations, do the following:

- Place the basin in a manual mode to override any automatic D.O./blower control systems.
- Adjust the grid(s) air control valve(s) to deliver an air flow rate equivalent to 0.5 scfm per diffuser or to a 25% open position if air flow metering is not available.
- AERATION TANK - Stop RAS flow to the basin.
- AEROBIC DIGESTER - Stop WAS flow to the basin.
- Turn off the air completely to the basin when the liquid level reaches 1 to 2 Ft. above the diffusers.
- When cleaning diffusers, the air can be turned on for short periods of time for the grid being cleaned.

**NOTE:** As the basin is draining, monitor the amount of air flowing to the submerged grid(s). **THE AIR FLOW SHOULD BE KEPT TO A MINIMUM. THIS WILL PREVENT EXCESS HEAT BUILD-UP FROM DAMAGING THE PVC OR CPVC PIPING SYSTEM WHILE KEEPING THE SOLIDS IN SUSPENSION.**

Refer to pages 27 and 28 for Diffuser Cleaning Procedure.

# YEARLY MAINTENANCE AND DIFFUSER CLEANING

## MAINTENANCE SCHEDULE

Sanitaire recommends the following maintenance schedule be observed at least once per year.

1. Drain down each tank.
2. Remove excess settled solids if any have accumulated.
3. Clean diffusers.
4. Inspect support hardware to ensure all components are intact and tight.
5. Inspect diffuser retaining rings to make sure all rings are in place and tight.
6. Inspect fixed and expansion joint retaining rings to make sure all rings are tight.

### NOTE

*For items 4-6, refer to the Installation Instructions.*

## LUBRICATION SCHEDULE

Since there are no moving parts on the SANITAIRE Fine Bubble Aeration Systems, a formal lubrication schedule is not required.

Three components require lubrication at the time of initial installation and future repairs. These components are:

- Ceramic Disc Diffuser "O"-Ring
- Membrane Disc Diffuser Retaining Ring
- Expansion Barrel, 4" Ø black "O"-Ring

Lubricate these items with the lubricants provided by Sanitaire and in accordance with the Installation Instructions.

## CERAMIC DISC DIFFUSER CLEANING METHOD

1. Drain aeration basin (the air should remain on as basin is drained).
2. With the air left on – at approximately 1 scfm (1.7 m<sup>3</sup>/hr) per diffuser – hose off each disc for twenty seconds with clean water at a nozzle pressure of 60 psig. Turn off the air supply when completed.
3. Put on the following safety equipment: eye goggles, rubber gloves, boots, sleeves, and apron. A breathing apparatus should be available in the event it is needed.

### ⚠ CAUTION

*Acid can be harmful if misused. Follow all manufacturers precautions and directions. Wear appropriate safety equipment. Do not breath acid vapors. Do not allow acid to make contact with eyes, skin or hair.*

4. Carefully prepare a 50% by volume solution of 18° baume muriatic acid. Always add the acid to water.
5. Using an acid resistant compression sprayer, apply a uniform covering of the acid solution to all diffuser elements.

### NOTE

*Do not spray the acid solution on the stainless steel supports and hardware.*

6. Allow the acid solution to sit on the diffusers for 30 minutes.
7. Turn the air back on at a rate of 1 scfm (1.7 m<sup>3</sup>/hr) per diffuser and repeat the hosing procedure for 10 seconds per diffuser.
8. Inspect the aeration system to determine if any hardware was loosened or broken during the cleaning.



## **YEARLY MAINTENANCE AND DIFFUSER CLEANING**

---

9. Review and follow the start-up procedure as found in the Installation and Start-up Section of this manual.

### **MEMBRANE DISC DIFFUSER CLEANING METHOD**

1. Drain aeration basin (the air should remain on as basin is drained).
2. With the air left on at approximately 1 scfm (1.7 m<sup>3</sup>/hr) per diffuser, hose off each disc for twenty seconds with a clean water source at a nozzle pressure of 60 psig.
3. Turn off the air flow to the aeration grid being cleaned.
4. If required, use a rag or soft bristle brush to scrub each diffuser to remove stubborn slime growth, chemical precipitates, or oils. Do not use acids or aggressive cleaners.
5. Turn the air back on at a rate of 1 scfm (1.7 m<sup>3</sup>/hr) per diffuser and repeat the hosing procedure for 10 seconds per diffuser.
6. Visually inspect the aeration system to determine if any hardware was loosened or broken during cleaning.
7. Review and follow the start-up procedure as found in the Installation and Start-up Section of this manual.

# LONG TERM STORAGE PROCEDURES

The following storage procedures are applicable to both fine bubble ceramic and membrane disc aeration systems.

The four options below were developed to protect the PVC pipe and diffusers from environmental damage, and are listed in order of preference.

## NOTE

*Prior to reading and determining a suitable long term storage method, it should be understood that Sanitaire assumes no responsibility for damage and cleaning requirements as a result of long term storage.*

## OPTION #1

For use when the aeration system is not in use and air is available.

### For warm climate storage:

1. Fill the tank with clean water to a level three feet above the PVC portion of the dropleg. This will give the pipe and diffusers protection from UV light and heat build-up.
2. Run a small amount of air through the system to keep the pipes empty and retard the growth of algae on the diffusers.
3. Chlorinate initially and periodically as algae appears in the water.
4. Prior to bringing the system on line, drain and check all hardware. Check the diffusers and clean if fouling is evident.

### For cold climate storage:

1. Follow warm climate procedures above after performing the following:

2. Prior to filling with water, install styrofoam blocks around the dropleg and carrier columns installed in the tank. These blocks will prevent crushing should ice build-up around the pipes.

## NOTE

*The operator may have to adjust the air flow rate to a higher level to prevent ice formation during severe cold temperatures.*

## OPTION #2

For use when the aeration system is not in use, air is not available, and diffusers are removed prior to storage.

### For warm climate storage:

1. Remove all diffusers, "O"-rings, retaining rings, sub plates, etc.; clean as required, and store in a clean, dry environment.
2. Fill the tank with clean water to a level three feet above the PVC portion of the dropleg.
3. Chlorinate initially and periodically as algae appears in the water.
4. Prior to bringing the system on line, drain and check all hardware. Check all diffuser holders and spot check pipe internals for algae growth and fouling. Clean as required prior to installing the diffusers.

### For cold climate storage:

1. Remove all diffusers, "O"-rings, retaining rings, sub plates, etc.; clean as required, and store in a clean, dry environment.
2. Install styrofoam blocks around the dropleg and carrier columns installed in the tank.



## LONG TERM STORAGE PROCEDURES

---

3. Fill the tank with clean water to a level three feet above the PVC portion of the dropleg.

### CAUTION

*Water will freeze in the tank. Do not drain the water from below the ice layer. Falling ice will crush the PVC pipe system.*

4. Wait until ice is completely off the tank prior to bringing the system on line. Check all diffuser holders and spot check pipe internals for algae growth and fouling, and clean as required prior to installing the diffusers.

### OPTION #3

For use when the aeration system is not in use, air is not available, and diffusers are not removed prior to storage.

The procedure here is identical to Option #2 except that the diffusers are **not removed**. This procedure applies to Idle Tanks Only. Intermittent use membrane disc systems in a flowing condition have been previously discussed in the Plant Operation and Preventative Maintenance sections of this manual.

### NOTE

*Be aware that the diffusers will most likely need to be cleaned prior to putting the system on line. In addition to spot checking the pipe internals, the underside of the diffuser should be spot checked to determine the extent of fouling, and if cleaning is required prior to use.*

### OPTION #4

For use when the aeration system is not in use, air is not available, diffusers are not removed, and flooding is undesirable.

1. Drain tanks dry.
2. Open fixed joints and loosen support band clamps as required in order to roll the air distributor sections over 180°.

### NOTE

*The fixed joints and floor drains should remain open to prevent water from standing in the pipe system and tank. Equipment flooded by overflows, misdirected sewage flows and excessive airborne dirt build-up will most likely require cleaning prior to being placed in service.*

### CAUTION

*The pipe will be exposed to UV light degradation and heat build-up in the tank bottom which may cause warping and loss of some structural properties.*

### CAUTION

*Standing water allowed to freeze around the pipe may break the pipe or may cause the diffusers (ceramic) to crack.*



# PIPE REPAIR PROCEDURES

## PROBLEM

- 1) 4"  $\varnothing$  PIPE SECTION BOKEN OFF.
- 2) 4"  $\varnothing$  PIPE CONNECTION CRACKED, MAY BE HARD TO DETECT UNTIL AIR IS TURNED ON.

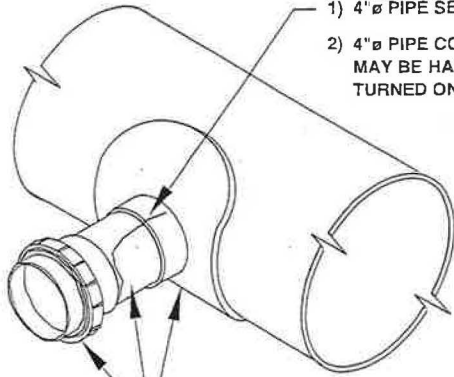

THREE SEPERATE COMPONENTS WITH SOLVENT CEMENTED JOINTS

## REPAIR

### STEP No. (1)

USE A RECIPROCATING TYPE SAW (SAWZALL) AND CUT THE PIPE SECTION OFF FLUSH WITH THE SADDLE AS SHOWN.

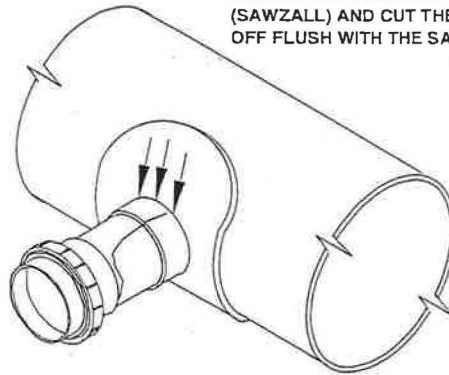

## REPAIR

### STEP No. (2)

- 1) CHAMFER THE INSIDE EDGE OF THE SADDLE OPENING TO REMOVE ANY SAW CUT PROJECTIONS.
- 2) FILE THE SADDLE OPENING, USE A HALF ROUND FILE.
- 3) FILE OFF THE SADDLE PROJECTION ON EACH SIDE OF THE OPENING.

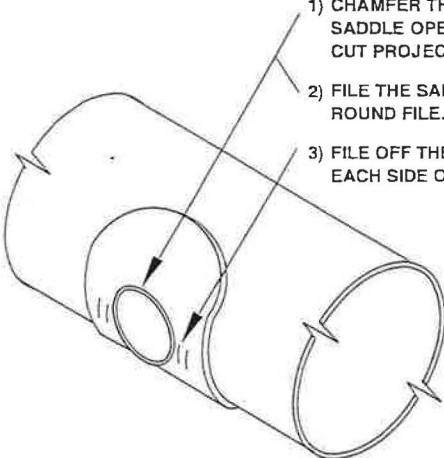

## REPAIR

### STEP No. (3)

- 1) DETERMINE THE MANIFOLD PIPE (O.D.) AND QUANTITY OF BROKEN OR CRACKED AIR DISTRIBUTOR CONNECTIONS.
- 2) ORDER THE APPROPRIATE SADDLE REPAIR ASSEMBLY FROM THE SUPPLIER.
- 3) CLEAN AND PRIME SURFACES PRIOR TO CEMENTING.
- 4) SOLVENT CEMENT THE NEW SADDLE ASSEMBLY DIRECTLY OVER THE EXISTING SADDLE USING A HEAVY BODY SOLVENT CEMENT.
- 5) SECURE SADDLE ASSEMBLY TO MANIFOLD WITH (SS) STRAP CLAMPS PROVIDED WITH REPAIR KIT.
- 6) ALLOW APPROPRIATE CURE TIME.

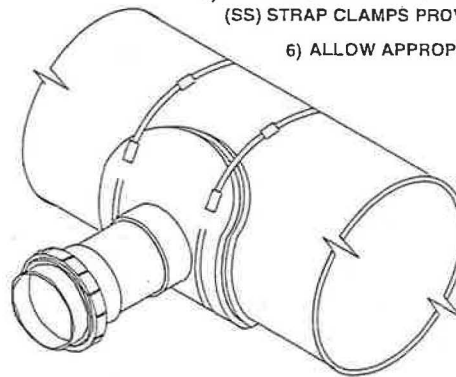

SAN A

MANIFOLD REPAIR – AIR DISTRIBUTOR CONNECTION SADDLE REPLACEMENT ON A 3-PIECE FABRICATED SADDLE ASSEMBLY

# PIPE REPAIR PROCEDURES

**PROBLEM**

1) SPIGOT & RETAINING RING END OF FIXED JOINT DAMAGED.  
4" Ø PIPE SECTION BETWEEN SADDLE & FIXED JOINT IS NOT DAMAGED.

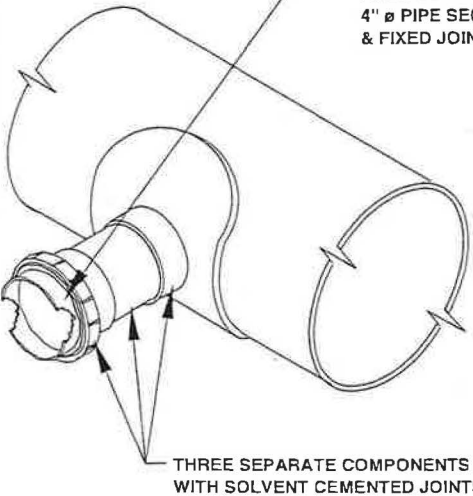

THREE SEPARATE COMPONENTS WITH SOLVENT CEMENTED JOINTS.

**REPAIR**

**STEP No. (1)**

- 1) CUT THE SPIGOT & RETAINING RING END OF THE FIXED JOINT OFF PERPENDICULAR TO THE CONNECTION AT A DISTANCE OF 1/2" (12 mm) FROM THE REAR END OF THE SOCKET FITTING.
- 2) DEBUR THE CUT PIPE END.

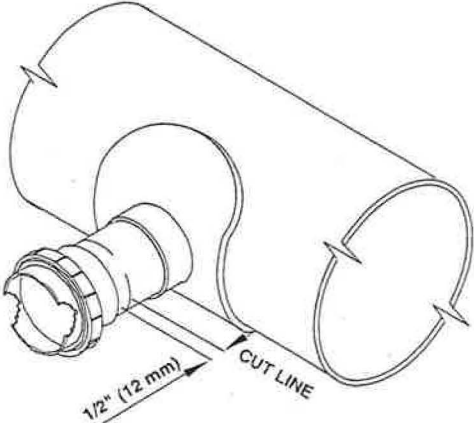

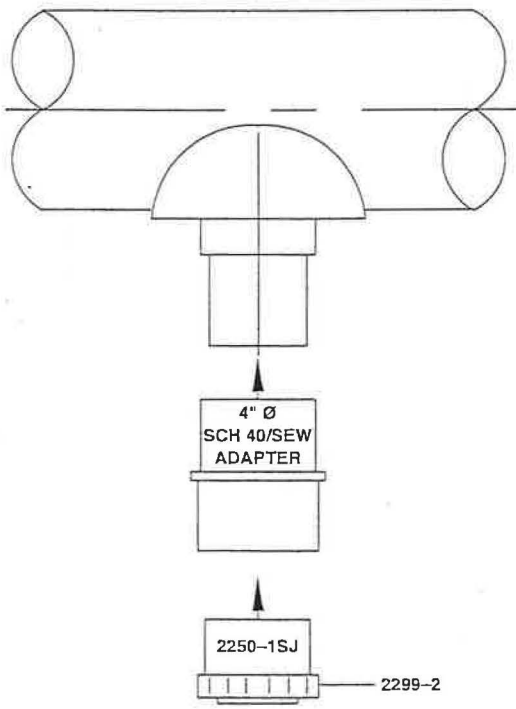

4" Ø  
SCH 40/SEW  
ADAPTER

2250-1SJ

2299-2

**REPAIR**

**STEP No. (2)**

- 1) OBTAIN THE REQUIRED QUANTITIES OF 4" Ø SCH 40 TO SEWER SIZE ADAPTERS AND SPIGOT & RETAINING RING ASSEMBLIES (2250-1SJ & 2299-2) FROM THE SUPPLIER.
- 2) CLEAN & PRIME THE CUT PIPE END AND THE SEWER SIZE SOCKET END OF THE SCH 40/SEWER SIZE ADAPTER.
- 3) SOLVENT CEMENT THE SCH 40/SEWER SIZE ADAPTER TO THE CUT PIPE END.
- 4) CLEAN & PRIME THE OUTSIDE FACE OF THE SPIGOT & RETAINING RING AND THE SCH 40 SOCKET END OF THE SCH 40/SEWER SIZE ADAPTER.
- 5) CAREFULLY SOLVENT CEMENT THE SPIGOT & RETAINING RING END OF THE FIXED JOINT INTO THE SCH 40 SOCKET END OF THE SCH 40/SEWER SIZE ADAPTER. THE RETAINING RING MUST BE FREE TO ROTATE. DO NOT ALLOW EXCESS GLUE TO COME IN CONTACT WITH THE RETAINING RING.

SAN B

## MANIFOLD REPAIR – SPIGOT & RETAINING RING AIR DISTRIBUTOR CONNECTION ON A 3-PIECE FABRICATED SADDLE ASSEMBLY

# PIPE REPAIR PROCEDURES

**PROBLEM**

- 1) 4"  $\varnothing$  PIPE SECTION VISIBLY BROKEN OFF.
- 2) 4"  $\varnothing$  PIPE SECTION CRACKED. MAY BE HARD TO DETECT UNTIL AIR IS TURNED ON.

**REPAIR**

STEP No. (1)

USE A RECIPROCATING TYPE SAW (SAWZALL) AND CUT THE PIPE SECTION OFF FLUSH WITH THE SADDLE AS SHOWN.

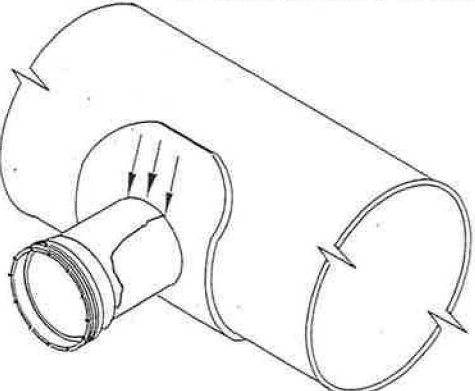
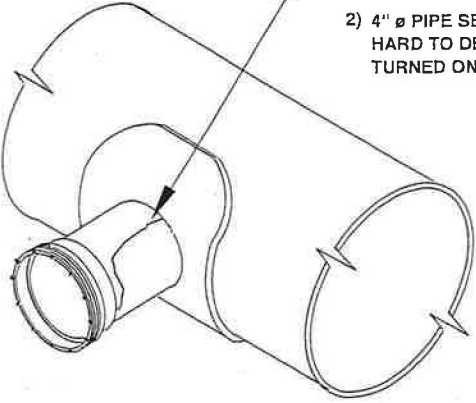

**REPAIR**

STEP No. (2)

- 1) CHAMFER THE INSIDE EDGE OF THE SADDLE OPENING TO REMOVE ANY SAW CUT PROJECTIONS.
- 2) THE CLEAR OPENING DIAMETER MUST BE 4-1/4" (108 mm) FOR PROPER FIT OF NEW SADDLE PIECE.

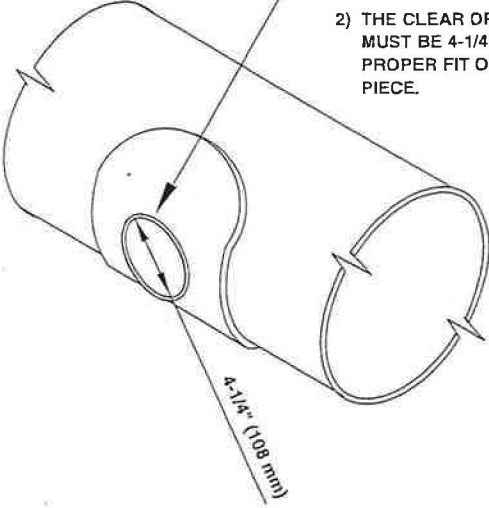

4-1/4" (108 mm)

**REPAIR**

STEP No. (3)

- 1) DETERMINE THE MANIFOLD PIPE (O.D.) AND QUANTITY OF BROKEN OR CRACKED PIPE CONNECTIONS.
- 2) ORDER THE APPROPRIATE SADDLE REPAIR ASSEMBLY FROM THE SUPPLIER.
- 3) CLEAN AND PRIME SURFACES PRIOR TO CEMENTING.
- 4) SOLVENT CEMENT. THE NEW SADDLE ASSEMBLY DIRECTLY OVER THE EXISTING SADDLE USING A HEAVY BODY SOLVENT CEMENT. MAKE SURE NEW SADDLE IS LEVEL TO PROPERLY ALIGN WITH AIR DISTRIBUTOR.
- 5) SECURE SADDLE ASSEMBLY TO MANIFOLD WITH (SS) STRAP CLAMPS PROVIDED WITH REPAIR KIT.
- 6) ALLOW APPROPRIATE CURE TIME.

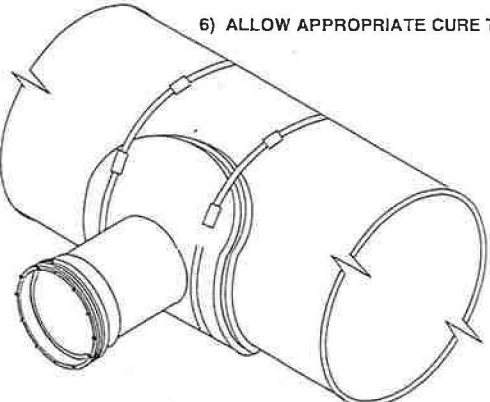

SAN C

MANIFOLD REPAIR – AIR DISTRIBUTOR CONNECTION SADDLE REPLACEMENT  
ON A 1-PIECE MOLDED SADDLE ASSEMBLY



SANITAIRE®

# PIPE REPAIR PROCEDURES

**PROBLEM**

1) SOCKET END OF FIXED JOINT CONNECTION IS DAMAGED. 4" Ø PIPE SECTION BETWEEN SADDLE AND JOINT IS NOT DAMAGED.

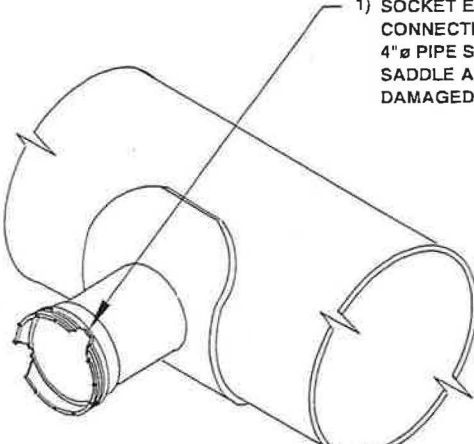

**REPAIR**

**STEP No. (1)**

1) CUT THE SOCKET END OF THE FIXED JOINT OFF PERPENDICULAR TO THE CONNECTION AT A DISTANCE OF 1-1/2" (38 mm) FROM THE FACE OF THE SOCKET END.

2) DEBUR THE CUT PIPE END.

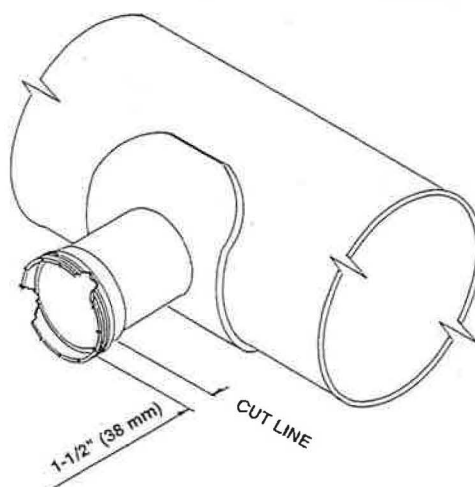

**REPAIR**

**STEP No. (2)**

1) OBTAIN THE REQUIRED QUANTITY OF FIXED JOINT SOCKETS (2250-3SJ) FROM THE SUPPLIER.

2) CLEAN & PRIME THE CUT PIPE END AND THE INSIDE OF THE SOCKET END FITTING.

3) SOLVENT CEMENT THE SOCKET END TO THE CUT PIPE END.

4) ALLOW ADEQUATE CURE TIME.

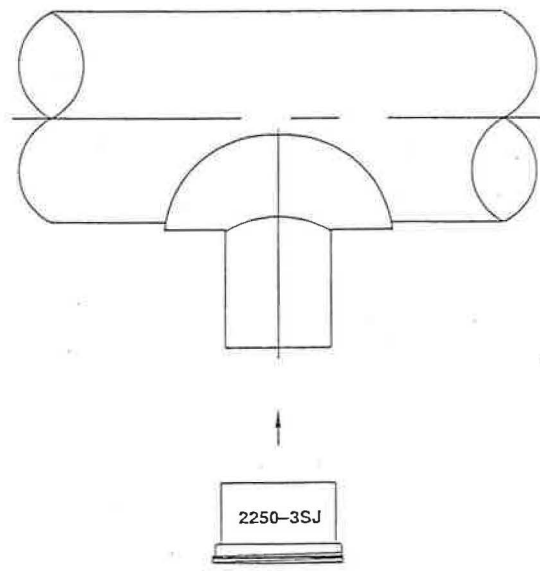

2250-3SJ

SAN D

MANIFOLD REPAIR – SOCKET AIR DISTRIBUTOR CONNECTION ON A 1-PIECE MOLDED SADDLE ASSEMBLY, 6" Ø – 10" Ø (150–250 mm Ø) MANIFOLDS



# PIPE REPAIR PROCEDURES

## PROBLEM

- 1) SOCKET END OF FIXED JOINT CONNECTION IS DAMAGED. 4" Ø PIPE SECTION BETWEEN SADDLE AND JOINT IS NOT DAMAGED.

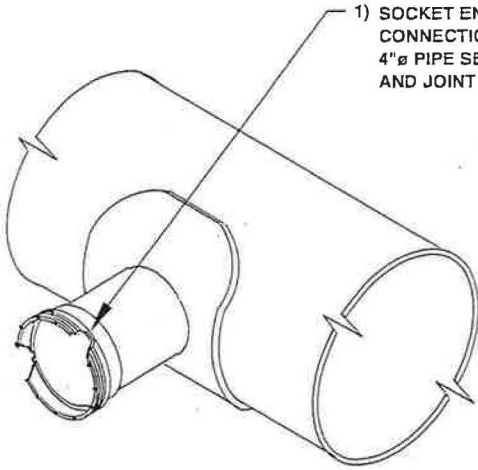

## REPAIR

### STEP No. (1)

- 1) CUT THE SOCKET END OF THE FIXED JOINT OFF PERPENDICULAR TO THE CONNECTION AT A DISTANCE OF 1-1/2" (38 mm) FROM THE FACE OF THE SOCKET END.

- 2) DEBUR THE CUT PIPE END.

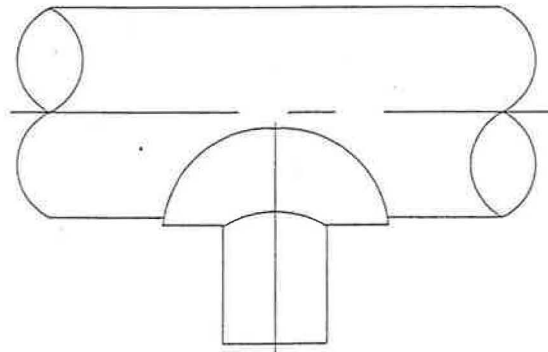
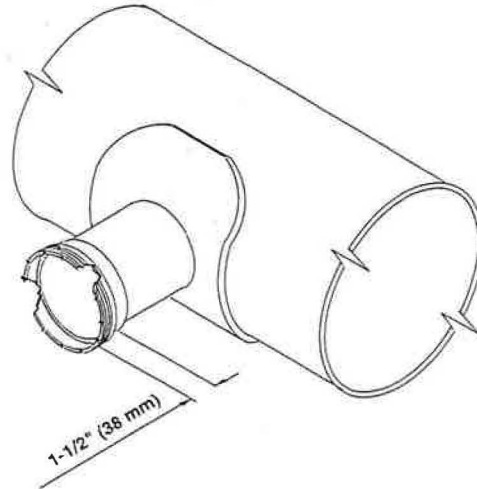

## REPAIR

### STEP No. (2)

- 1) OBTAIN THE REQUIRED QUANTITY OF MODIFIED FIXED JOINT SOCKETS (2250-3SJ) FROM THE SUPPLIER. (1" OF SOCKET REMOVED)
- 2) CLEAN & PRIME THE CUT PIPE END AND THE INSIDE OF THE SOCKET END FITTING.
- 3) SOLVENT CEMENT THE SOCKET END TO THE CUT PIPE END.
- 4) ALLOW ADEQUATE CURE TIME.

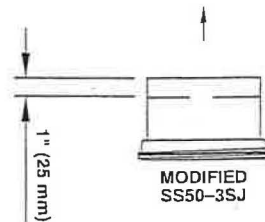

SAN E

MANIFOLD REPAIR – SOCKET AIR DISTRIBUTOR CONNECTION ON A 1-PIECE MOLDED SADDLE ASSEMBLY, 12" Ø (300 mm Ø) MANIFOLDS

# PIPE REPAIR PROCEDURES

## PROBLEM

CRACKED MANIFOLD PIPE SECTION.

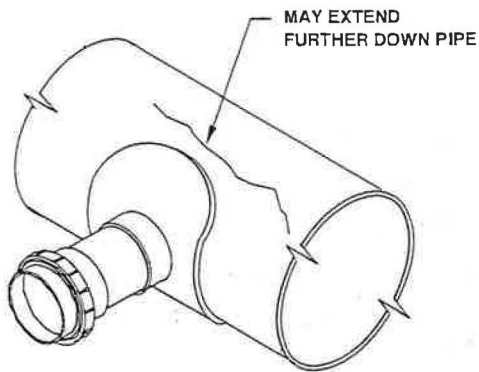

## REPAIR

STEP No. (2)

- 1) DETERMINE AND ORDER THE REQUIRED REPAIR PARTS FROM THE SUPPLIER.
- 2) CUT A LENGTH OF REPAIR PIPE OF THE CORRECT DIAMETER AND QUANTITY OF PIPE SADDLES.
- 3) THE ENDS MUST BE CUT SQUARE.
- 4) DE-BURR THE ENDS OF THE PIPE.

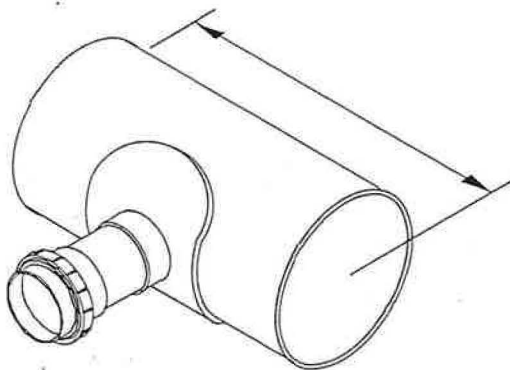

## REPAIR

STEP No. (1)

CUT THE BROKEN PIPE SECTION OUT OF THE MANIFOLD BETWEEN SADDLES. THE CUT MUST BE PERPENDICULAR TO THE CENTER OF PIPE.

REMOVE SAW CUT BURRS BY FILING OR SANDING THE OUTSIDE EDGE OF THE PIPE.

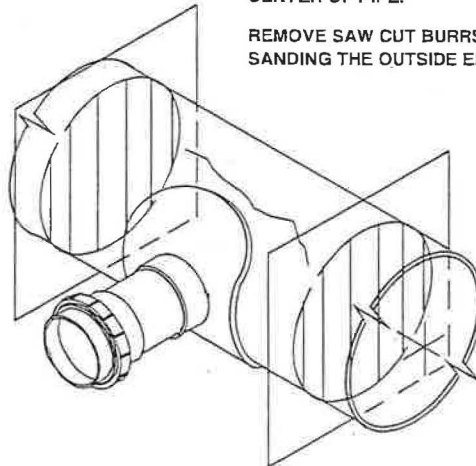

## REPAIR

STEP No. (3)

- 1) OBTAIN THE PROPER SIZE AND TYPE OF PVC COUPLINGS.
- 2) SOLVENT CEMENT THE REPAIR SECTION TO THE COUPLINGS AS REQUIRED. USE A HEAVY BODY SOLVENT CEMENT AND COMPATIBLE PRIMER TO MAKE GLUE JOINTS.
- 3) SOLVENT CEMENT THE REPAIR SECTION TO THE ORIGINAL MANIFOLD SECTIONS. MAKE SURE THE MANIFOLD AIR DISTRIBUTOR CONNECTIONS ARE LEVEL.

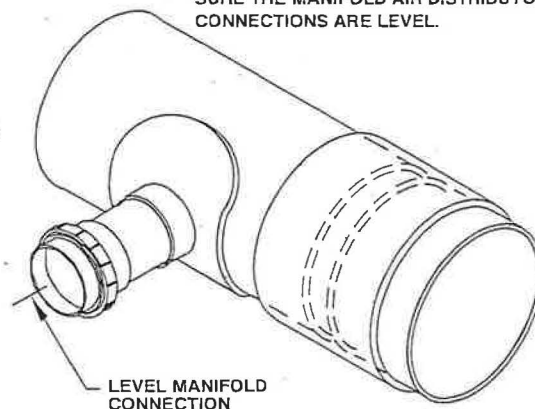

SAN F

## MANIFOLD REPAIR – CRACKED MANIFOLD PIPE SECTION



# PIPE REPAIR PROCEDURES

## PROBLEM

- 1) IN-LINE MANIFOLD AIR DISTRIBUTOR CONNECTION INSTALLED OUT OF HORIZONTAL LEVEL CAUSING AIR DISTRIBUTOR TO BE OUT OF LEVEL. (SHOWN ON SKETCH)
- 2) RAISED MANIFOLD AIR DISTRIBUTOR CONNECTION INSTALLED OUT OF VERTICAL PLUMB CAUSING AIR DISTRIBUTOR TO BE OUT OF LEVEL.

## REPAIR

### STEP No. (1)

USE A RECIPROCATING TYPE SAW (SAWZALL) AND CUT THE SPIGOT SECTION OFF FLUSH WITH THE SADDLE AS SHOWN.

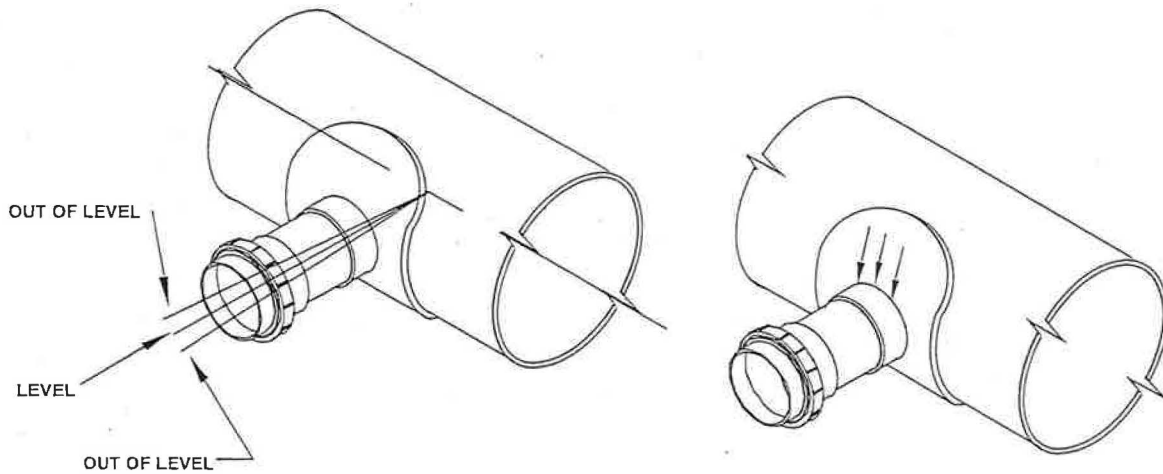

## REPAIR

### STEP No. (2)

- 1) REFER TO DRAWING SAN A IF THE AIR DISTRIBUTOR CONNECTION IS A FABRICATED 3-PIECE SADDLE WITH A SPIGOT AND RETAINING RING.
- 2) REFER TO DRAWING SAN C IF THE AIR DISTRIBUTOR CONNECTION IS A MOLDED 1-PIECE SADDLE WITH A SOCKET FITTING.

SAN G

## MANIFOLD REPAIR – MISALIGNED AIR DISTRIBUTOR CONNECTION



# PIPE REPAIR PROCEDURES

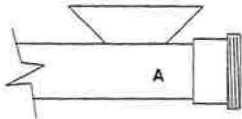

## PROBLEM

DAMAGED FIXED JOINT OR EXPANSION JOINT

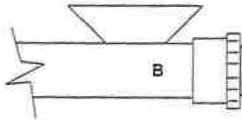

A) FIXED JOINT SOCKET 2250-3SJ

B) FIXED JOINT SPIGOT 2250-1SJ  
FIXED JOINT RETAINING RING 2299-2

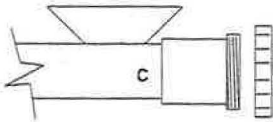

C) EXPANSION JOINT BARREL 2306-1XS  
EXPANSION JOINT RETAINING RING 2306-2XR

\* 2250-3 IS A SPLINED SOCKET  
\* 2250-1 IS A NOTCHED SPIGOT

## REPAIR

STEP No. (1)

REMOVE DAMAGED JOINT END BY CUTTING THE ATTACHED PIPE SECTION AT A DISTANCE OF (1/2") FROM THE END OF THE FITTING.

CARE SHOULD BE TAKEN TO MAKE CUT AS SQUARE AS POSSIBLE.

DE-BURR PIPE END.

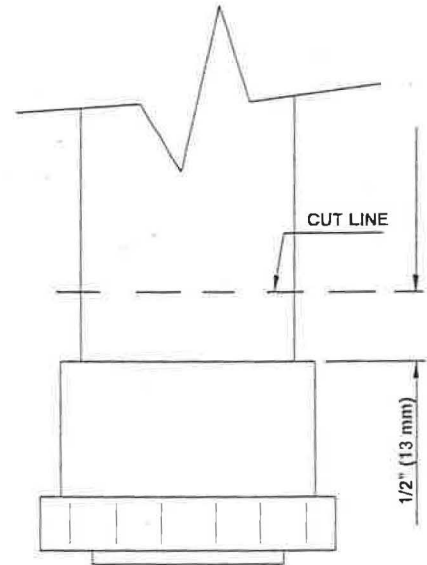

## REPAIR

STEP No. (2)

- 1) OBTAIN THE REQUIRED QUANTITY OF REPAIR PARTS FROM SUPPLIER.
- 2) CLEAN AND PRIME CUT PIPE END.
- 3) CLEAN AND PRIME THE INSIDE OF THE SMALL OR SEWER SIZE END OF A PVC SCH 40/SEWER ADAPTOR.
- 4) SOLVENT CEMENT THE PIPE ADAPTOR TO THE PIPE END.
- 5) CLEAN AND PRIME THE OPPOSITE END OF THE SCH 40/SEWER ADAPTOR.
- 6) CLEAN AND PRIME THE OUTSIDE FACE OF THE REQUIRED JOINT REPAIR END.
- 7) SOLVENT CEMENT THE JOINT END INTO SCH 40/SEWER PIPE ADAPTOR.

### NOTE:

IF A SPIGOT AND RETAINING RING IS USED. DO NOT PUSH THE SPIGOT SO FAR INTO THE PIPE ADAPTOR WHERE FREE ROTATION OF THE RETAINING RING IS PROHIBITED. THE RETAINING RING MUST BE FREE TO ROTATE.

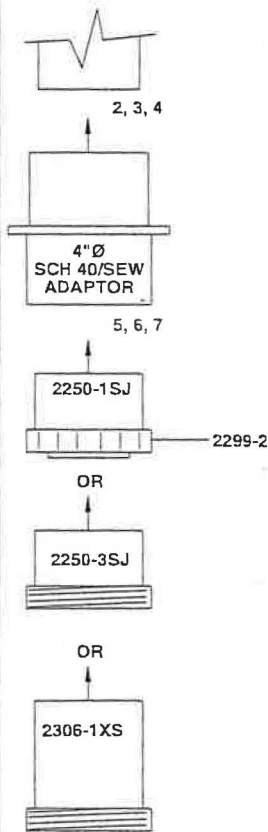

SAN H

AIR DISTRIBUTOR REPAIR – DAMAGED FIXED JOINT SPIGOT END, SOCKET END OR EXPANSION JOINT SOCKET END

# PIPE REPAIR PROCEDURES

## PROBLEM

PIN HOLE LEAK AROUND THE EDGE OF THE AIR DISTRIBUTOR PIPE CONNECTION SADDLE AS EVIDENT BY AIR RELEASE AT START-UP

## REPAIR

STEP No. (1)

1) APPLY A BEAD OF HEAVY BODY SOLVENT CEMENT AROUND THE EDGE OF THE PIPE SADDLE.

2) ALLOW ADEQUATE CURE TIME.

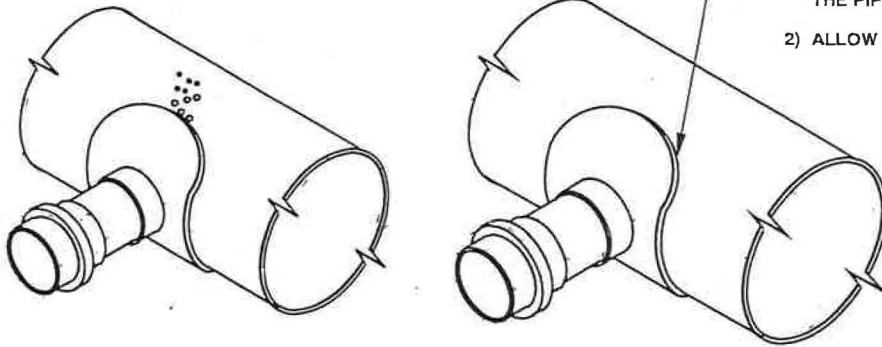

SAN I

## MANIFOLD REPAIR – PIN HOLE LEAK AROUND THE EDGE OF THE AIR DISTRIBUTOR SADDLE CONNECTION

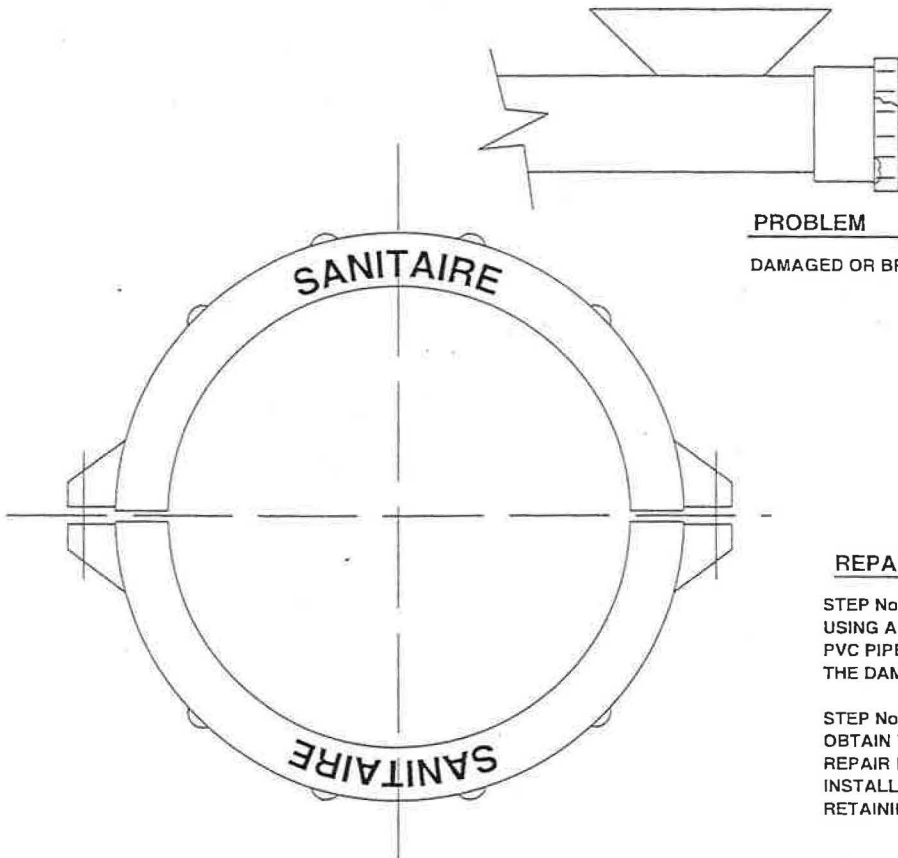

## PROBLEM

DAMAGED OR BROKEN RETAINING RING(2299-2)

## REPAIR

STEP No. (1)

USING A HAND HELD HACKSAW OR PVC PIPE SAW CAREFULLY CUT-OFF THE DAMAGED RETAINING RING.

STEP No. (2)

OBTAIN THE REQUIRED QUANTITY OF REPAIR RINGS FROM THE SUPPLIER. INSTALL NEW SPLIT FIXED JOINT RETAINING RING No.2299-REP

SAN J

## AIR DISTRIBUTOR REPAIR – DAMAGED FIXED JOINT RETAINING RING



**SANITAIRE®**

# PIPE REPAIR PROCEDURES

## PROBLEMS

- (A) CRACKED AIR DISTRIBUTOR PIPE.
- (B) CRACKED DIFFUSER HOLDER.
- (C) CHIPPED DIFFUSER HOLDER.
- (D) OUT OF ROUND DIFFUSER HOLDER (RARE) WILL NOT SEAL.
- (E) DIFFUSER HOLDER BROKEN OFF.

THE REPAIR OF THE ABOVE LISTED PROBLEMS INVOLVES CUTTING OUT AND REPLACING A PIPE SECTION. THE NUMBER OF DIFFUSERS THAT REQUIRE REMOVAL WILL VARY DEPENDING ON THE EXTENT OF THE DAMAGE.

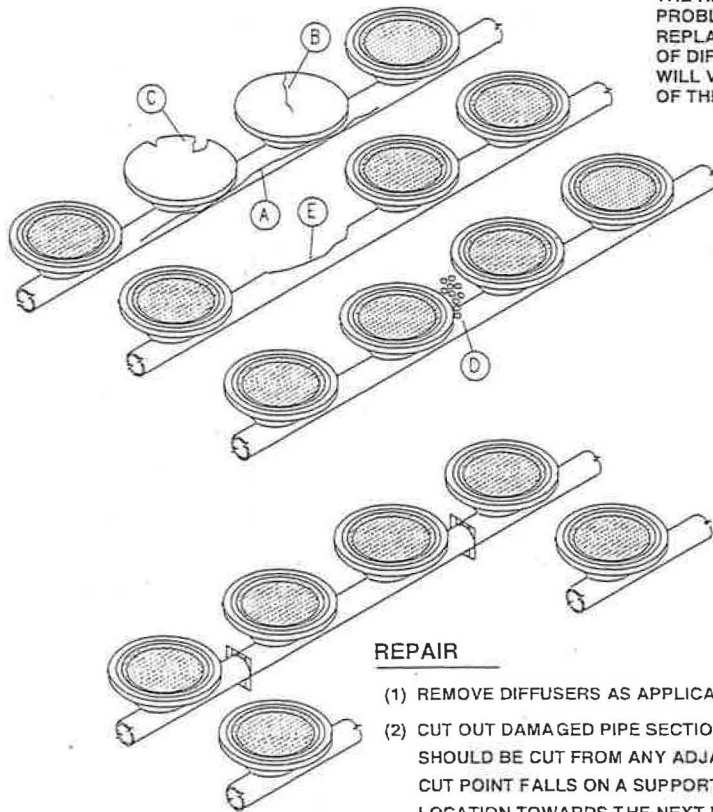

## REPAIR

- (1) REMOVE DIFFUSERS AS APPLICABLE FROM DAMAGED PIPE SECTION.
- (2) CUT OUT DAMAGED PIPE SECTION. THE MINIMUM DISTANCE THE PIPE SHOULD BE CUT FROM ANY ADJACENT DIFFUSER IS 6" (150 mm). IF THE CUT POINT FALLS ON A SUPPORT LOCATION MOVE OFF THE SUPPORT LOCATION TOWARDS THE NEXT DIFFUSER IF SPACING ALLOWS OR MOVE DOWN TO SPACE BETWEEN NEXT DIFFUSER FOR TIGHTLY SPACED DIFFUSERS.
- (3) FROM A SPARE DISTRIBUTOR SECTION OR REPAIR MATERIALS SENT BY THE SUPPLIER CUT A SECTION TO THE REQUIRED LENGTH WITH THE APPROPRIATE NUMBER OF DIFFUSERS AT THE CORRECT DIFFUSER SPACING.
- (4) DEBUR, CLEAN AND PRIME ALL CUT ENDS.
- (5) USE TWO 4" PVC SEWER SIZE COUPLINGS AND SOLVENT CEMENT THE REPAIR PIPE SECTION INTO PLACE.
- (6) ALL DIFFUSERS MUST BE KEPT ON THE SAME PLANE.
- (7) ALLOW APPROPRIATE CURE TIME. INSTALL THE DIFFUSERS, TIGHTEN ANY SUPPORTS THAT MAY HAVE BEEN LOOSENED, TEST AND PUT BACK IN SERVICE.

SAN K

AIR DISTRIBUTOR REPAIR – DAMAGED DIFFUSER HOLDER OR PIPE AND OBSTACLE, PIPE RE-ROUTING REQUIREMENTS



## PIPE REPAIR PROCEDURES

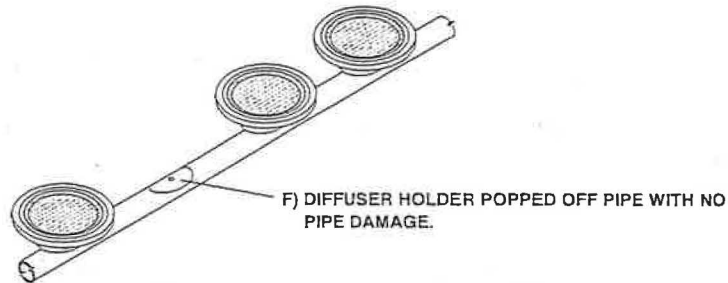

- 1) CLEAN HOLDER AREA OF ANY OLD SOLVENT CEMENT RESIDUE.
- 2) PRIME HOLDER AREA AND BOTTOM OF DIFFUSER HOLDER.
- 3) USE A HEAVY BODY SOLVENT CEMENT AND ATTACH HOLDER ON PIPE.
- 4) ALLOW APPROPRIATE CURE TIME.

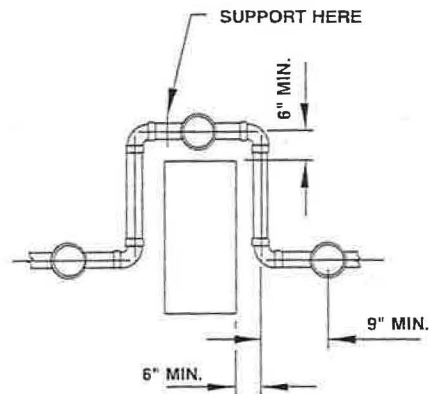

### PROBLEM

G) AIR DISTRIBUTOR INSTALLATION REQUIRES ROUTING AROUND AN OBSTACLE

### REPAIR

USE 90° SEWER SIZE PVC SOCKET ELBOWS, SANITAIRE P.N. 4SEW-EL9 AND 4.215"O.D. SEWER PIPE TO MAKE NECESSARY MODIFICATIONS.

MAKE SURE THE OFFSET AIR DISTRIBUTOR RUN IS ADEQUATELY SUPPORTED.

SAN L

AIR DISTRIBUTOR REPAIR – DAMAGED DIFFUSER HOLDER OR PIPE AND OBSTACLE,  
PIPE RE-ROUTING REQUIREMENTS (Continued)



# Sanitaire

---



## ITT Industries

[www.sanitaire.com](http://www.sanitaire.com)

Corporate Office: 9333 N. 49<sup>th</sup> Street  
Brown Deer, WI 53223  
Tel 414 365 2200  
Fax 414 365 2210

Branch Office: 71 Elm Street  
Worcester, MA 01609  
Tel 508 752 0998  
Fax 508 754 7377